

**PARTS FOR:  
VACUUM CLEANER INDUSTRIAL 30ltr 1500w/230v  
STAINLESS BIN  
MODEL: PC300SD.V3**

ITEM	PART NO	DESCRIPTION
1	PC300SD.V3-01	WHEEL COVER
2	PC300SD.V3-02	WHEEL
3	PC300SD.V3-03	WHEEL SURROUND
4	PC300SD.V3-04	WATERSPOUT COVER
5	PC300SD.V3-05	SEAL RING
6	PC300SD.V3-06	WATERSPOUT
7	PC300SD.V3-07	PC300SD.V3-07
8	PC300SD.V3-08	WATERSPOUT SEAT
9	PC300SD.V3-09	TANK
10	PC300SD.V3-10	HOSE INLET
11	PC300SD.V3-11	HOSE INLET BASE
12	PC300SD.V3-12	BIN CLIP
13	PC300SD.V3-13	LOWER COVER
14	PC300SD.V3-14	FOAM RING
15	PC300SD.V3-15	SILENCER SPONGE
16	PC300SD.V3-16	FLOAT
17	PC300SD.V3-17	TRAY
18	PC300SD.V3-18	PLASTIC FENCE
19	PC300SD.V3-19	SEAL RING
20	PC300SD.V3-20	MOTOR
21	PC300SD.V3-21	CAPACITOR & INDUCTANCE
22	PC300SD.V3-22	SEAL RING
23	PC300SD.V3-23	SILENCER FOAM
24	PC300SD.V3-24	AIR BLOCK BOARD
25	PC300SD.V3-25	SILENCER FOAM
26	PC300SD.V3-26	AIR OUTLET
27	PC300SD.V3-27	DAMPING BAR
28	PC300SD.V3-28	SEAL
29	PC300SD.V3-29	AIR BLOCK BOARD
30	PC300SD.V3-30	SWITCH
31	PC300SD.V3-31	LOWER HANDLE
32	PC300SD.V3-32	UPPER HANDLE
33	PC300SD.V3-33	UPPER COVER
34	PC300SD.V3-34	SILENCER FOAM
35	PC300SD.V3-35	LABEL
36	PC300SD.V3-36	NAMEPLATE
37	PC300SD.V3-37	SILENCER FOAM
38	PC300SD.V3-38	FILTER COVER
39	PC300SD.V3-39	FOAM FILTER
40	PC300SD.V3-40	CORD CLAMP
41	PC300SD.V3-41	CABLE SLEEVE
43	PC300SD.V3-43	HOOK BASE
44	PC300SD.V3-44	TANK BASE
45	PC300SD.V3-45	CASTOR
46	PC300SD.V3-46	WHEEL SHAFT
47	PC300SD.V3-47	BOLT
48	PC300SD.V3-48	WASHER
49	PC300SD.V3-49	SCREW (ST2.9 x 12)
50	PC300SD.V3-50	SCREW (ST4.2 x 14)
51	PC300SD.V3-51	SCREW (ST5.3 x 8)

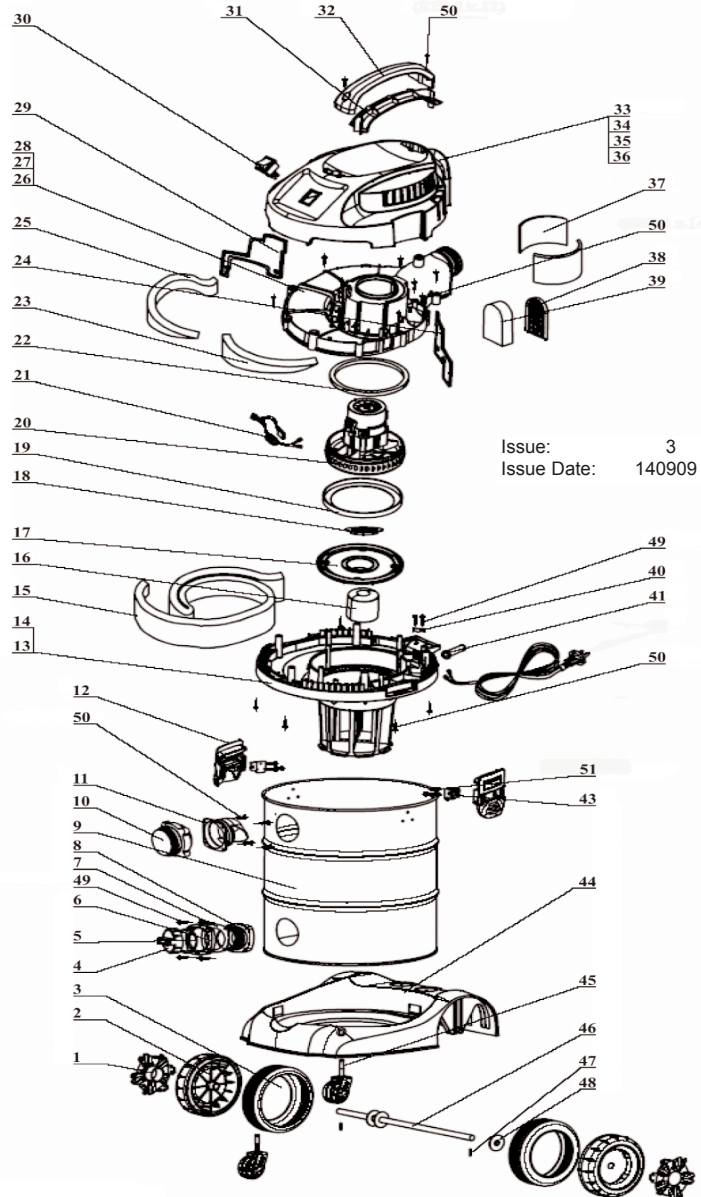

ITEM	PART NO	DESCRIPTION
52	PC300SD.V3-52	HOSE 1.5MM
53	PC300SD.V3-53	TELESCOPIC STAINLESS TUBE
54	PC300SD.V3-54	CREVICE TOOL
55	PC300SD.V3-55	ADJUSTABLE TUBE, AIR
56	PC300SD.V3-56	COMBO BRUSH
57	PC300SD.V3-57	NOISE DIFFUSER MUFFLER
58	PC200CFL	LOCKING CARTRIDGE FILTER
59	PC200FF10	FOAM FILTER (pack of 10)
	PC300PB5	DUST BAGS (pack of 5) "OPTIONAL" (not shown)



**NOTE:** It is our policy to continually improve products and as such we reserve the right to alter data, specifications and component parts without prior notice.

**IMPORTANT:** No liability is accepted for incorrect use of product.

**WARRANTY:** Guarantee is 12 months from purchase date, proof of which will be required for any claim.

**INFORMATION:** For a copy of our latest catalogue and promotions call us on 01284 757525 and leave your full name and address, including postcode.