

Thank you for purchasing a Sealey product. Manufactured to a high standard this product will, if used according to these instructions and properly maintained, give you years of trouble free performance.



IMPORTANT: READ THESE INSTRUCTIONS CAREFULLY. NOTE THE SAFE OPERATIONAL REQUIREMENTS, WARNINGS AND CAUTIONS. USE THIS PRODUCT CORRECTLY AND WITH CARE FOR THE PURPOSE FOR WHICH IT IS INTENDED. FAILURE TO DO SO MAY CAUSE DAMAGE AND/OR PERSONAL INJURY AND WILL INVALIDATE THE WARRANTY. RETAIN THESE INSTRUCTIONS FOR FUTURE USE.

1. SAFETY PRECAUTIONS

1.1. GENERAL SAFETY INSTRUCTIONS.

- ✓ Read the operator's manual carefully before using your workbench.
- x **DO NOT** open more than one drawer at a time.
- x **DO NOT** step on the drawers.
- x **DO NOT** let children near the workbench.
- ✓ Ensure drawers are fully closed and self locking catch is activated before moving the workbench.
- ✓ Secure brakes when rollcab is in the desired position.

2. INTRODUCTION AND SPECIFICATIONS

Heavy gauge steel with double wall construction for extra strength and durability. Fitted with oversized, heavy-duty Ø160mm wheels, two fixed and two locking castors. Ball bearing drawer runners provide superior performance and carry heavier loads. Each drawer fitted with catch to prevent unexpected opening when being transported around the workshop. Added security provided by side mounted cylinder lock. Supplied with two keys for drawers. Unique design incorporates perforated side panels for hanging tools and accessories. Ideally suited for the Premier range of themed tool trays. Rust and solvent resistant powder coat paint finish. Fitted with anti-shock protection on all four corners to prevent accidental damage. Heavy-duty metal work top makes these units very durable and a great workstation.

		AP24212		AP24216	
Overall Size (W x D x H)		1130 x 565 x 1000		1130 x 565 x 1000	
Drawers (W x D x H)	Qty	(W x D x H)	Qty	(W x D x H)	
Medium Drawer	3	533 x 391 x 58	6	533 x 391 x 58	
Large Drawer	2	533 x 391 x 128	2	533 x 391 x 128	
X-Large Drawer	1	533 x 391 x 195			
Medium 1/2 Drawer	3	268 x 391 x 58	6	268 x 391 x 58	
Large 1/2 Drawer	2	268 x 391 x 128	2	268 x 391 x 128	
X-Large 1/2 Drawer	1	533 x 391 x 195			

Optional Accessories	
Model No	Description
AP24ACC2	Side Shelf with Paper Roll Holder
AP24ACC3	Document Holder
AP24ACC4	Waste Bin
AP24ACC5	Can and Bottle Holder
AP24ACC6	Drawer Divider 3 x 395 x 58mm
AP24ACC7	Drawer Divider 3 x 395 x 120mm
AP24ACC9	Short Hook Set x 10pcs
AP24ACC10	Medium Hook Set x 10pcs

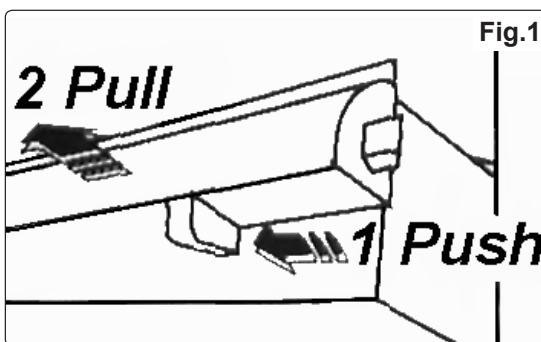

Fig.1

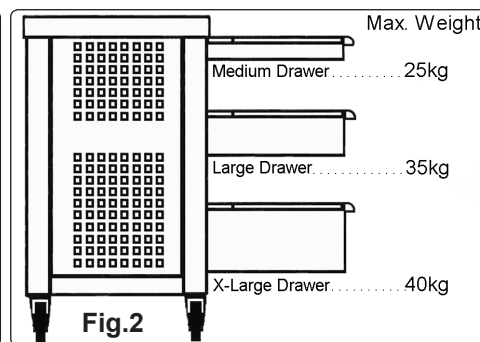

Fig.2

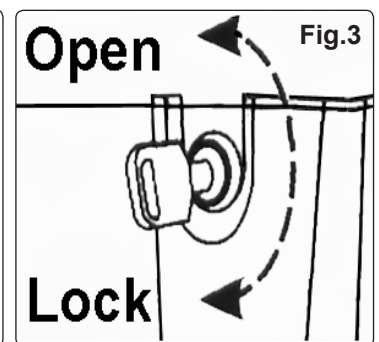

Fig.3

3. OPERATION

- 3.1 Each drawer is fitted with a catch mechanism on the right hand side of the drawer underneath the handle, to open drawer push the catch to the left to release the catch and pull the drawer open (fig.1).

WARNING! Only open one drawer at a time and **DO NOT** overload the drawers, Fig.2.

- 3.2 When moving the workbench, ensure that the drawers are closed and locked (fig.3) to prevent accidental opening, release the brakes as shown in fig.4 and move the workbench using the handles and maintain full control. When the workbench has been moved to the required location, lock the brakes.

WARNING! DO NOT move across slopes of more than 5 degrees as the workbench may tilt.

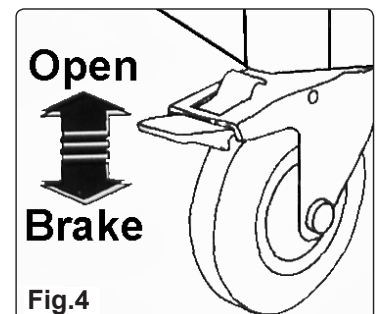

Fig.4

NOTE: It is our policy to continually improve products and as such we reserve the right to alter data, specifications and component parts without prior notice.

IMPORTANT: No liability is accepted for incorrect use of product.

WARRANTY: Guarantee is 12 months from purchase date, proof of which will be required for any claim.

INFORMATION: For a copy of our latest catalogue and promotions call us on 01284 757525 and leave your full name and address, including postcode.