

5. PARTS LIST

Issue: 3
Date Issued: 210405

ITEM	PART NO.	DESCRIPTION
1	ER1700P/01	LOCKING CAP
2	ER1700P/02	LOCKING PIN
3	ER1700P/03	SPRING
4	ER1700P/04	GEAR HOUSING
5	ER1700P/05	BRASS BUSHING
6	ER1700P/06	RETAINING RING
7	DAS150T/07	SPIRAL BEVEL GEAR
8	DAS150T/08	RETAINING RING
9	B/6201ZZ	BEARING
11	DAS150T/11	BEARING BOX
12	DAS150T/12	SCREW PAN HD M4x16 c/w SPRING
13	ER1700P/12	WOODRUFF KEY
14	DAS150T/14	SPINDLE
14-1	DAS150T/14-1	SCREW M6
15	DAS150T/15	ALUMINIUM COVER
16	DAS150T/16	ECCENTRIC SHAFT
18	DAS150T/18	RETAINING RING
19-3	DAS150T.PSK	PAD SPINDLE KIT (PARTS 17/19/19-1/19-2)
20	ER1700P/20	SCREW
21	ER1700P/21	NUT
22	DAS150T/22	PINION GEAR
23	B/6000ZZ	BEARING
24	ER1700P/24	BEARING COVER
25	ER1700P/25	SCREW
27	DAS150T/27	ARMATURE ASS'Y
28	B/608LLB	BEARING
28-1	DAS150T.28-1	O-RING
29	ER1700P/29	SCREW
30	DAS150T/30	FIELD ASSY
31	ER1700P/31	MOTOR HOUSING
32	ER1700P/32	SWITCH LEVER
33	ER1700P/33	C'BON BRUSH HOLDER
34	ER1700P/34	CARBON BRUSH
35	ER1700P/35	CARBON BRUSH CAP
36	ER1700P/36	SWITCH BASE
37	ER1700P/37	SCREW
38	ER1700P/38	SWITCH
39	ER1700P/39	SCREW
40	ER1700P/40	STRAIN RELIEF
41	ER1700P/41	SCREW
42	ER1700P/42	SWITCH PULL ROD
43	ER1700P/43	SPRING

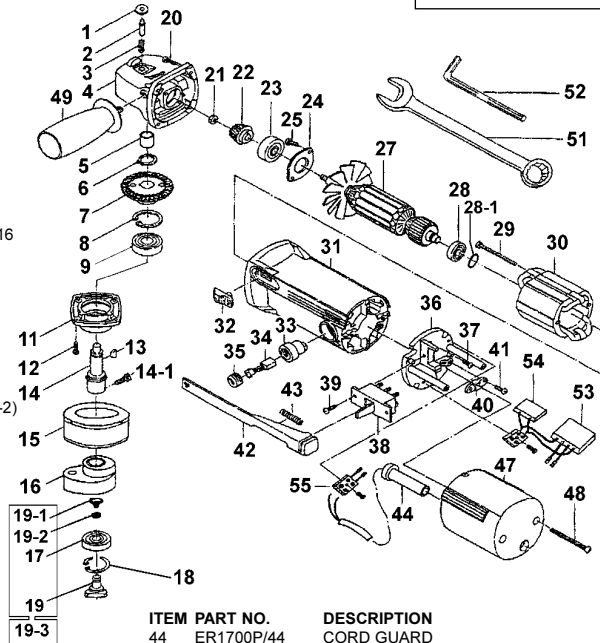

ITEM	PART NO.	DESCRIPTION
44	ER1700P/44	CORD GUARD
46	CS 2.5M2CBLK	POWER SUPPLY CORD
47	ER1700P/47	REAR COVER
48	ER1700P/48	SCREW
49	ER1700P/49	SIDE HANDLE
50	DAS150T/50	PAD
51	AK378/17S	17MM COMBI WRENCH
52	AK93-5	5MM HEX WRENCH
53	ER1700P/53-54	EMC PARTS
54	ER1700P/53-54	EMC PARTS
55	ER1700P/55	TERMINAL BLOCK

6. DECLARATION OF CONFORMITY

Declaration of Conformity We, the sole importer into the UK, declare that the products listed here are in conformity with the following standards and directives. The construction files for these products are held by the Manufacturer and may be inspected, by a national authority, upon request to Jack Sealey Ltd.

DUAL ACTION SANDER Models: DAS150T & DAS150T/DFS

73/23/EEC Low Voltage Directive
89/336/EEC EMC Directive
98/37/EC Machinery Directive
93/68/EEC CE Marking Directive



Signed by Mark Sweetman

15th April 2003

For Jack Sealey Ltd. Sole importer into the UK of Sealey Power Tools.

NOTE: It is our policy to continually improve products and as such we reserve the right to alter data, specifications and component parts without prior notice. **IMPORTANT:** No liability is accepted for incorrect use of this equipment. **WARRANTY:** Guarantee is 12 months from purchase date, proof of which will be required for any claim. **INFORMATION:** For a copy of our latest catalogue and promotions call us on 01284 757525 and leave your full name and address, including postcode.



Sole UK Distributor, Sealey Group, Bury St. Edmunds, Suffolk.

01284 757500 01284 703534 sales@sealey.co.uk www.sealey.co.uk



INSTRUCTIONS FOR:
DUAL ACTION SANDER

MODELS: **DAS150T & DAS150T/DFS**

Thank you for purchasing a Sealey product. Manufactured to a high standard this product will, if used according to these instructions and properly maintained, give you years of trouble free performance.



IMPORTANT: PLEASE READ INSTRUCTIONS CAREFULLY. NOTE THE SAFE OPERATIONAL REQUIREMENTS, WARNINGS AND CAUTIONS. USE THIS PRODUCT CORRECTLY AND WITH CARE FOR THE PURPOSE FOR WHICH IT IS INTENDED. FAILURE TO DO SO MAY CAUSE DAMAGE AND/OR PERSONAL INJURY AND WILL INVALIDATE THE WARRANTY. PLEASE KEEP INSTRUCTIONS SAFE FOR FUTURE USE.

1. SAFETY INSTRUCTIONS

1.1. Electrical Safety

- WARNING!** It is the user's responsibility to read, understand and comply with the following:
 - You must** check all electrical equipment and appliances to ensure they are safe before using.
 - You must** inspect power supply leads, plugs and all electrical connections for wear and damage.
 - You must** ensure the risk of electric shock is minimised by the installation of appropriate safety devices. An RCCB (Residual Current Breaker) should be incorporated in the main distribution board. We also recommend that an RCD (Residual Current Device) is used with all electrical products. It is particularly important to use an RCD with portable products that are plugged into an electrical supply not protected by an RCCB. If in doubt consult a qualified electrician. You may obtain a Residual Current Device by contacting your Sealey dealer. **You must** also read and understand the following instructions concerning electrical safety.
- 1.1.1. The Electricity At Work Act 1989 requires all portable electrical appliances, if used on business premises, to be tested by a qualified electrician, using a Portable Appliance Tester (PAT), at least once a year.
- 1.1.2. The Health & Safety at Work Act 1974 makes owners of electrical appliances responsible for the safe condition of the appliance and the safety of the appliance operator. If in doubt about electrical safety, contact a qualified electrician.
- 1.1.3. Ensure the insulation on all cables and the product itself is safe before connecting to the mains power supply. See 1.1.1. & 1.1.2. above and use a Portable Appliance Tester (PAT).
- 1.1.4. Ensure that cables are always protected against short circuit and overload.
- 1.1.5. Regularly inspect power supply leads and plugs for wear and damage and all electrical connections to ensure that none is loose.
- 1.1.6. Important: Ensure the voltage marked on the product is the same as the electrical power supply to be used and check that plugs are fitted with the correct capacity fuse. A 13 amp plug may require a fuse smaller than 13 amps for certain products, see fuse rating below.
- 1.1.7. **DO NOT** pull or carry the appliance by the power supply lead.
- 1.1.8. **DO NOT** pull power plugs from sockets by the power cable.
- 1.1.9. **DO NOT** use worn or damaged leads, plugs or connections. Immediately replace or have repaired by a qualified electrician. A U.K. 3 pin plug with ASTA/BS approval is fitted. In case of damage, cut off and fit a new plug according to the following instructions, discard old plug safely (UK only - see diagram at right). Ensure the unit is correctly earthed via a three-pin plug.
 - a) Connect the green/yellow earth wire to the earth terminal 'E'.
 - b) Connect the brown live wire to live terminal 'L'.
 - c) Connect the blue neutral wire to the neutral terminal 'N'.
 After wiring, check that there are no bare cores, that all wires have been correctly connected, that the cable external insulation extends beyond the cable restraint and that the restraint is tight. Double insulated products are fitted with live (BROWN) and neutral (BLUE) wires only. Double insulated products are always marked with this symbol . Check your model carefully to see which type of product you have. To re-wire a double insulated item, connect the brown and blue wires as indicated above. **DO NOT** connect brown or blue to the earth terminal.
- 1.1.10. Cable extension reels. When a cable extension reel is used it should be fully unwound before connection. A cable reel with an RCD fitted is recommended since any product which is plugged into the cable reel will be protected. The section of the cores of the cable is important and should be at least 1.5mm², but to be absolutely sure that the capacity of the cable reel is suitable for this product and for others that may be used in the other output sockets, we recommend the use of 2.5mm² section cable.

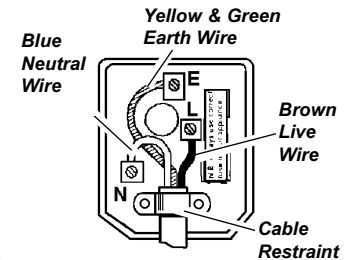

FUSE RATING
THIS PRODUCT MUST BE
FITTED WITH A
5 AMP FUSE

1.2. General Safety

- WARNING!** Ensure Health & Safety, local authority, and general workshop practice regulations are adhered to when using this equipment.
- WARNING!** Disconnect from mains power before changing accessories or servicing.

- ✓ Maintain the sander in good condition (use an authorised service agent).
- ✓ Replace or repair damaged parts. *Use genuine parts only. Unauthorised parts may be dangerous and will invalidate the warranty.*
- ✓ Use sander in a suitable work area. Keep area clean, tidy and free from unrelated materials. Ensure that there is adequate lighting.
- ✓ Before use, check abrasive pad condition. If worn or damaged replace immediately.
- ☐ **WARNING!** Always wear approved eye or face protection when operating the sander.
- ✓ If dust is generated, use face, dust, or respiratory protection in accordance with COSHH regulations.
- ✓ Depending on use, sander noise level may exceed 85dB - in which case wear safety ear defenders.
- ✓ Remove ill fitting clothing, ties, watches, rings, other loose jewellery and contain and/or tie back long hair.
- ✓ Wear appropriate protective clothing and keep hands and body clear of moving parts.
- ✓ Maintain correct balance and footing. Ensure the floor is not slippery and wear non-slip shoes.
- ✓ Keep children and unauthorised persons away from the work area.
- ✓ Always use the sander with the side handle securely assembled.
- ✓ Ensure the workpiece is correctly secured before operating the sander. Never hold workpiece by hand and check the workpiece to ensure there are no protruding nails, screws, rivets, etc.
- ✓ Avoid unintentional starting.
- ✓ DAS150T/DFS - switch off the sander before you switch off the dust collection system.
- x **DO NOT** use the sander for a task it is not designed to perform.
- x **DO NOT** operate sander if any parts are damaged or missing. This may cause failure and/or injury.
- ☐ **WARNING! DO NOT** sand any materials containing asbestos.
- x **DO NOT** carry the sander by the electrical cable, or, in the case of DAS150T/DFS, the dust hose.
- x **DO NOT** connect DAS150T/DFS to a standard vacuum cleaner to extract dust as damage to the cleaner may result.
- x **DO NOT** get the sander wet or use in damp or wet locations.
- x **DO NOT** use sander with water, the sander is for dry use only.
- x **DO NOT** operate sander if you are tired or under the influence of alcohol, drugs or intoxicating medication.
- x **DO NOT** use where there are flammable liquids, solids or gases such as paint solvents or waste wiping or cleaning rags.
- x **DO NOT** leave the sander running unattended.
- x **DO NOT** carry the sander with your finger on the power switch.

Risk of Hand Arm Vibration Injury.

The DAS150T & DAS150T/DFS Dual Action Sanders, when operated in accordance with these instructions and tested in accordance with EN 28662-2: 1994 results in the following vibration emission declared in accordance with BS EN12096: 1996. Measured vibration emission value:.....5.5m/s² Uncertainty:2.2m/s²

These values are suitable for comparison with emission levels of other tools that have been subject to the same test. This tool may cause hand-arm vibration syndrome if its use is inadequately managed.

Recommended Measures to reduce risk of hand-arm vibration syndrome:

This tool should not be used by an individual regularly for more than 202 minutes in any 8 hour period. This duration of use should be reduced if the individual is exposed to hand-arm vibration from other sources.

LEAD PAINT WARNING!

Paint once contained lead as a traditional ingredient. The dust from the removal of such paint is toxic if inhaled or ingested and must, therefore, be avoided. The following action must be taken before using the sander on a surface that you suspect may have contained lead in the paint.

1. User must determine potential hazard relating to age of paint to be removed. (Modern paints do not contain lead).
2. **DANGER!** Keep all persons and pets away from the work area. The following are particularly vulnerable to the effects of lead paint dust: *Expectant women, babies and children.*
3. We recommend personal protection by using the following safety items:
 - a) Paint Spray Respirator (Sealey ref: SSP16EN)
 - b) PE Coated Hooded Coverall (Sealey ref: SSP266)
 - c) Latex Gloves (Sealey ref: SSP24)
4. Take adequate measures to contain the paint dust, flakes, and scrapings.
5. Continue to wear safety equipment as in 3 above, and thoroughly clean all areas when task is complete. Ensure that paint waste is disposed of, in sealed bags or containers, according to local authority regulations.



2. ASSEMBLY & SPECIFICATIONS

The DAS150T and DAS150T/DFS have alloy gear housings, composite motor housings and brush caps for quick brush replacement. Both units have slider On/Off switches with power lock. Discs and pads for DAS150T/DFS have holes through which dust is extracted. This unit must be connected to a dust extraction system. Contact your Sealey dealer for details. **DO NOT use a standard vacuum cleaner to extract dust as damage to the cleaner may result.**

2.1. Assembly

☐ **WARNING! DO NOT plug sander into the mains power supply before the machine is assembled.**

Unpack the sander and check contents against figure 1. Should there be any damaged or missing parts (note that sanding pads and the extractor cowl for DAS150T/DFS are not shown) contact your supplier immediately. Screw handle (1) into the hole (right or left side, as required) in the head (2). Screw the sanding pad into the spindle (A).

To remove pad, hold spindle with the spanner (3) whilst unscrewing the pad.

Hex key (4) is for removal of eccentric shaft (B) for cleaning etc.

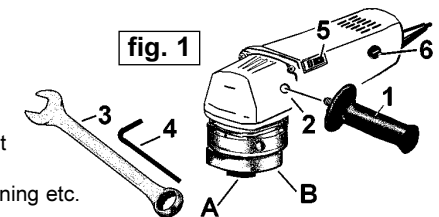

2.2. Specifications

DAS150T & DAS150T/DFS

Power230V - 400W
 No load speed6500rpm
 Orbit size8 mm
 PadØ150mm
 Thread5/16"UNF
 Weight2.3 kg
 Vibration5.5m/s²

PADS

DAS150T - Pad No. PTC/150A, PTC/150SA (supplied) or PTC/150VA.
DAS150T/DFS - Pad No. AK289 (supplied) or AK290.

Note:

DAS150T may be converted for use with dust free systems. Contact your Sealey dealer for details.

3. OPERATING INSTRUCTIONS

☐ **WARNING! Before use, ensure that you have read and understood Section 1 Safety Instructions.**

- 3.1. Attach the correctly rated sanding disc (not supplied) to the sanding pad.
- 3.2. Plug the sander into the mains power supply.
- 3.3. Grip the side handle and turn on by pushing switch (fig 1.5) forward. Let go of the switch and the machine will continue running.
- 3.4. To release the switch, and stop the sander, press down on the rear section of the switch - it will spring to the Off position.
- 3.5. Check that the unit is working correctly before use.

Note: The sander is designed for dry use only. **DO NOT** use with water or any other liquids.

4. MAINTENANCE

☐ **WARNING! Disconnect sander from power supply before changing accessories, servicing or performing maintenance. Replace or repair any damaged parts. Use genuine parts only, unauthorised parts may be dangerous and will invalidate the warranty.**

- 4.1. After each 50 hours use (or as required), remove dust by blowing air through the side vents and around the pad bearing. Periodic cleaning will prolong machine life.
- 4.2. Change pads when required. Ensure pad and disc RPM ratings are equal to, or exceed the machine rating. If the disc becomes unbalanced, it will cause the bearings to wear.
- 4.3. Check brushes every 200 hours of use. To access, remove plastic plugs located on each side of sander (fig1.6), taking care not to lose brush springs. Change brushes when worn to half original length or if cracked or damaged. Failure to do so will damage armature and cause arcing.
- 4.4. All other service and maintenance must be carried out by an authorised service agent.
- 4.5. When not in use store in a safe, dry, childproof location.