

Thank you for purchasing a Sealey product. Manufactured to a high standard this product will, if used according to these instructions and properly maintained, give you years of trouble free performance.

! **IMPORTANT: PLEASE READ THESE INSTRUCTIONS CAREFULLY. NOTE THE SAFE OPERATIONAL REQUIREMENTS, WARNINGS & CAUTIONS. USE THIS PRODUCT CORRECTLY AND WITH CARE FOR THE PURPOSE FOR WHICH IT IS INTENDED. FAILURE TO DO SO MAY CAUSE DAMAGE AND/OR PERSONAL INJURY AND WILL INVALIDATE THE WARRANTY. PLEASE KEEP INSTRUCTIONS SAFE FOR FUTURE USE.**

1. SAFETY INSTRUCTIONS

1.1 GENERAL SAFETY

- ✓ Familiarise yourself with this products application and limitations, as well as the specific potential hazards peculiar to the press.
- ✓ Maintain the press in good condition (use an authorised service agent).
- ✓ Replace or repair damaged parts. *Use recommended parts only. Non authorised parts may be dangerous and will invalidate the warranty.*
- ✓ Keep the press clean for best and safest performance.
- ✓ Locate the press in a suitable working area for its function, keep area clean, tidy, free from unrelated materials and ensure there is adequate lighting.
- ✓ Ensure the workpiece is correctly secured before operating the press.
- ❑ **WARNING!** Always wear approved eye or face protection when operating the press.
- ✓ Remove ill fitting clothing. Remove ties, watches, rings, loose jewellery and contain long hair.
- ✓ Keep hands and body clear of the work table when operating the press.
- ✓ Maintain correct balance and footing. Ensure the floor is not slippery and wear non slip steel toe-capped shoes/boots.
- ✓ Keep children and unauthorised persons away from the working area.
- x **DO NOT** operate the press if any parts are missing as this may cause failure or possible personal injury.
- x **DO NOT** use to compress springs or any other item that could disengage and cause a potential hazard.
- x **DO NOT** stand directly in front of the loaded press and never leave a loaded press unattended.
- x **DO NOT** force the press to achieve a task it was not designed to perform.
- x **DO NOT** make any modifications to the press.
- x **DO NOT** adjust or tamper with the safety valve.
- x **DO NOT** exceed the rated capacity of the press.
- x **DO NOT** apply off centre loads.
- x **DO NOT** allow the workpiece or the arbor plates to fall from the press working bench.
- x **DO NOT** get the press wet or use in damp or wet locations or areas where there is condensation.
- x **DO NOT** operate the press when you are tired, under the influence of alcohol, drugs or intoxicating medication.
- ✓ When not in use release pressure from the pump and clean the press. Stand or store the arbors in a safe location.
- ❑ **WARNING!** Always position the press against a wall. If the press is situated in the open workshop, it is essential that a guard be placed at the rear of the unit. This will prevent injury to bystanders in the event of the work piece ejecting suddenly.
- ❑ **WARNING!** The warnings, cautions and instructions in this manual cannot cover all possible conditions and situations that may occur. It must be understood by the operator that common sense and caution are factors which cannot be built into this product, but must be applied by the operator.
- ▲ **DANGER!** The press is top heavy. If it requires moving after assembly or for relocation, use suitable slings around the top crossbeam, or lift direct with a forklift with the forks located under the top crossbeam. **DO NOT** use a pallet truck.

2. INTRODUCTION & SPECIFICATIONS

Steel frame construction with hydraulic pump unit. Sliding hydraulic ram assembly gives 260mm of lateral travel for off-centre pressing applications. Frame head fitted with ram pressure gauge. Supplied with flat pressing plate/V-blocks.

Model:	YK30F.V2
Type:	Floor
Capacity:	30ton
Ram Stroke:	150mm
Lateral Ram Travel:	260mm
Maximum Height - Ram to Table:	1131mm
Minimum Height - Ram to Table:	52mm
Table Aperture:	164mm
Working Table Depth:	188mm
Working Table Width:	550mm
Overall Height:	1975mm
Gauge Included:	Yes
Weight:	177kg



3. ASSEMBLY

3.1 YK30F.V2 30TON PRESS ASSEMBLY (use the exploded diagram (Fig.1) as a guide to assembly).

- 3.1.1 Attach the two upper cross beams (20) to the left and right posts (09) using bolts (16), washers (17), lock washers (18) and nuts (19).
- 3.1.2 Attach one of the base sections (01) to the left post and lower cross member (08) using bolts (07), washers (04), lock washers (05) and nuts (06). Add two supports (02) to the post and base sections, using bolts (03), washers (04), lock washers (05) and nuts (06). Repeat the operation for the right hand side.
- 3.1.3 Lifting from the upper cross beam end lift the press into an upright position.
- ☐ **WARNING!** Ensure help is available and use slings and a suitable hoist or gantry to raise the press to an upright position.
- 3.1.4 Insert the bed frame pins (10) into the holes in each of the post, ensuring that they are level and then with the help of an assistant insert the bed frame (11) into the press frame and rest on to the pins.
- 3.1.5 Attach the pump to the right hand post using bolts (25) and washers (26).
- 3.1.6 Attach the ram assembly to the upper cross beam using bolts (21), washers (04), lock washers (05) and nuts (06).
- 3.1.7 Connect the hydraulic hose (37) to the ram (15) (A to A) and assemble the pressure gauge (23) to the ram assembly (B to B).

Fig.1

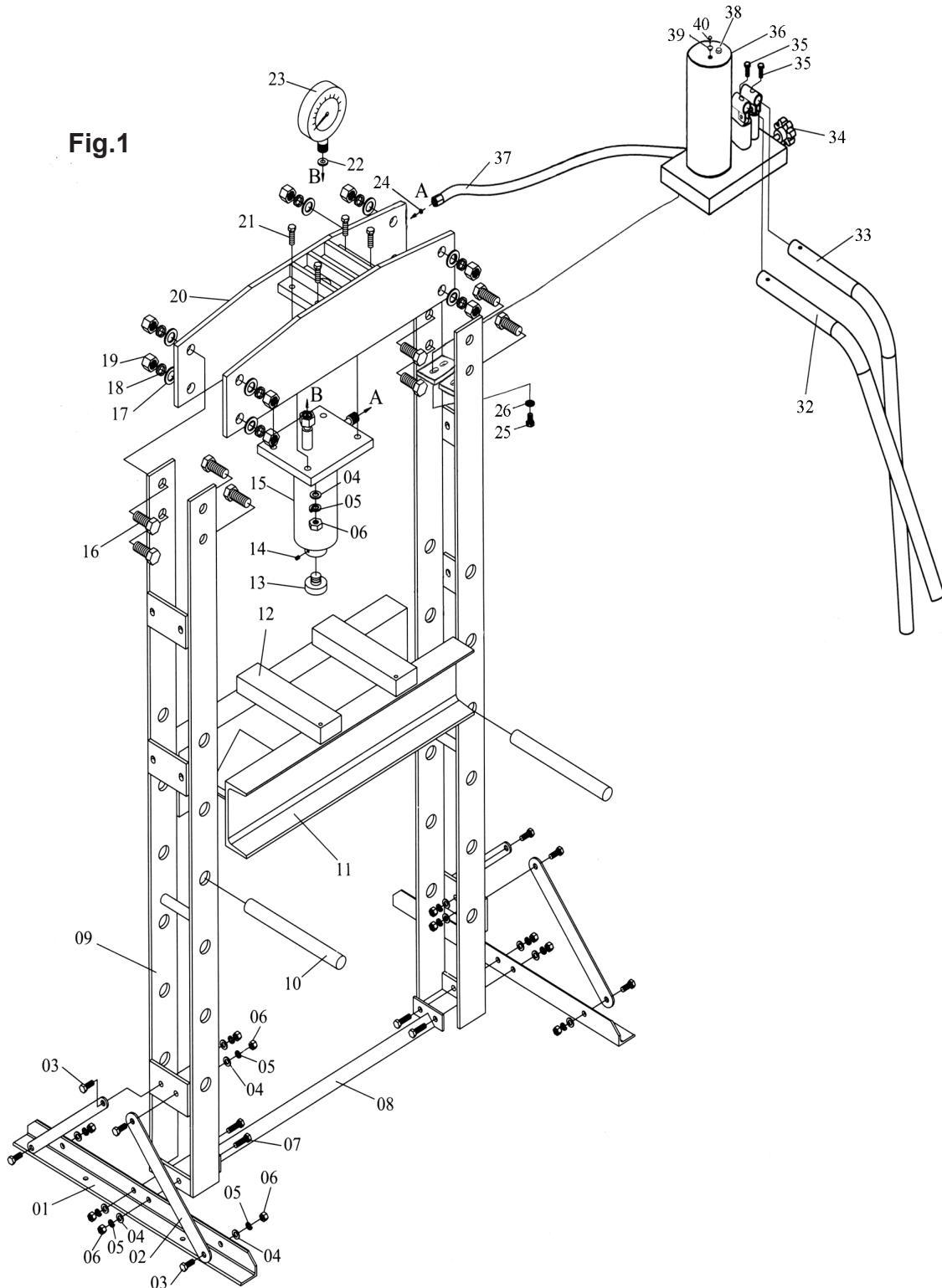

4. INSTALLATION & OPERATING

4.1 INSTALLATION.

4.1.1 Securely attach the press to a flat, firm, level surface taking into account clearance for working pieces.

▲ **DANGER! The press is top heavy.** If it requires moving after assembly or for relocation, use suitable slings around the top crossbeam, or lift direct with a forklift with the forks located under the top crossbeam. **DO NOT** use a pallet truck.

4.1.2 Purge hydraulic system.

Before operating the press, the hydraulic system may require purging in order to eliminate any air that may have built up during transit. Open the release valve (34) by turning anti-clockwise and pump the handle (32) several times.

Should the system malfunction at any time, repeating this procedure may resolve the problem.

▲ **DANGER! Press is purpose designed to withstand greater loads than the hydraulic units can develop. For safety reasons, always ensure the workpiece is secured on the table to ensure loads that flex will not suddenly "give" causing danger to operator or damage to component. Ensure you have read and understood chapter 1 safety instructions.**

4.2 OPERATING INSTRUCTIONS.

4.2.1 Position the work table at the required operating height by inserting the support pins into the appropriate holes in the main frame.

4.2.2 Place the support blocks (12) onto work table (11), then place the workpiece onto the support blocks and align beneath the ram as required. **Note:** care must be taken to ensure a support block does not fall from the press work table. If necessary hold the configuration in position with clamps.

4.2.3 Close the release valve (34) by turning it clockwise until it is firmly closed.

4.2.4 Pump handle (32) to quickly bring the ram into position on the workpiece. Before applying any pressure to the workpiece, recheck the alignment with the ram and ensure that the workpiece and press tools are supported in such a way that they cannot flex.

☐ **WARNING! DO NOT** apply off centre loads.

4.2.5 Use the pump handle (33) for smaller more controlled movements and applying load onto workpiece.

4.2.6 When work is done, stop pumping the handle. Slowly and carefully free load from workpiece by turning the release valve (34) anti-clockwise in small increments. **Note:** Always keep the piston retracted after use to avoid ram corrosion.

4.2.7 Once ram has fully retracted, remove workpiece from work table.

Note: Always keep the piston retracted after use.

5. MAINTENANCE

Note: Maintenance and repair must only be carried out by qualified person. Contact your Sealey dealer for details.

5.1 Periodically lubricate all joints and moving parts.

5.2 Always keep the press clean, dry, and protected from harsh conditions.

5.3 Before checking the oil level make sure the ram is fully retracted. Remove the oil filler plug (39) from the top of the pump. The oil level should be just below the bottom of the filler hole. If it needs filling, use only Sealey hydraulic jack oil. (DO NOT use brake fluid. Contact your local Sealey dealer for details). Replace oil filler nut and purge system of air (see 4.1.2).

5.4 When replacing the hydraulic oil, ensure the piston is fully retracted.

5.5 If press efficiency begins to drop, purge the system to eliminate any air from the hydraulic system (see 4.1.2).

5.6 When not in use, store the press in a dry, childproof location with the ram and piston fully retracted.

IMPORTANT: NO RESPONSIBILITY IS ACCEPTED FOR INCORRECT USE OF THE PRESS.

Hydraulic products are only repaired by local service agents. We have service/repair agents in all parts of the UK.

DO NOT RETURN PRODUCT TO SEALEY. Please telephone Sealey on 01284 757500 to obtain the address and phone number of your local agent.

If product is under guarantee please contact your dealer.

De-commissioning Product

Should the product become completely unserviceable and require disposal, draw off the oil into an approved container and dispose of the product and the oil according to local regulations.

6. DECLARATION OF CONFORMITY

Declaration of Conformity We, the sole importer into the UK, declare that the product listed below is in conformity with the following EEC standards and directives.

**Hydraulic Floor Press
Model: YK30F.V2**

2006/42/EC Machinery Directive
93/68/EEC CE Marking Directive



The construction file for this product is held by the Manufacturer and may be inspected on request by contacting Jack Sealey Ltd

Signed by Mark Sweetman

21st October 2008

For Jack Sealey Ltd. Sole importer into the UK of Sealey Quality Machinery

NOTE: It is our policy to continually improve products and as such we reserve the right to alter data, specifications and component parts without prior notice.

IMPORTANT: No liability is accepted for incorrect use of product.

WARRANTY: Guarantee is 12 months from purchase date, proof of which will be required for any claim.

INFORMATION: For a copy of our latest catalogue and promotions call us on 01284 757525 and leave your full name and address, including postcode.



Sole UK Distributor,
Sealey Group,
Bury St. Edmunds,
Suffolk.



01284 757500



01284 703534



www.sealey.co.uk



sales@sealey.co.uk