

UNIVERSAL TROLLEY FOR PORTABLE MIG WELDERS

Thank you for purchasing a Sealey product. Manufactured to a high standard this product will, if used according to these instructions and properly maintained, give you years of trouble free performance.



IMPORTANT: PLEASE READ THESE INSTRUCTIONS CAREFULLY. NOTE THE SAFE OPERATIONAL REQUIREMENTS, WARNINGS, AND CAUTIONS. USE THIS PRODUCT CORRECTLY, AND WITH CARE FOR THE PURPOSE FOR WHICH IT IS INTENDED. FAILURE TO DO SO MAY CAUSE DAMAGE AND/OR PERSONAL INJURY AND WILL INVALIDATE THE WARRANTY.

1. SAFETY INSTRUCTIONS

- x **DO NOT** put more than one bottle on the trolley.
- ✓ Always seat the bottle in the upright position.
- ✓ Always secure the bottle tightly to the trolley with the chains provided.
- ✓ Only use the trolley on firm, level, unobstructed surfaces which are capable of supporting the trolley and its load.
- x **DO NOT** use the trolley on sloping surfaces.
- x **DO NOT** allow others to ride on the trolley.
- x **DO NOT** attempt to move the trolley by pulling on the earth or torch cable.
- x **DO NOT** attach the welder's earth clamp to the metal frame of the trolley as this may result in accidental arcing from the torch.
- ✓ Replace or repair damaged parts. *Use only recommended parts. Unauthorised parts may be dangerous and will invalidate the warranty.*
- ✓ Store gas cylinders in a vertical position only and ensure the storage area is correctly secured.
- x **DO NOT** store gas cylinders in areas where temperature exceeds 50°C. **DO NOT** use direct heat on a cylinder. Always keep gas cylinders cool.
- x **DO NOT** attempt to repair or modify any part of a gas cylinder or valve, and **DO NOT** puncture or damage a cylinder.
- x **DO NOT** obscure or remove any official labels from a cylinder. Always check the gas identity before use.
- x Avoid getting gas cylinders oily or greasy.
- x **DO NOT** try to lift or handle cylinder by its cap, guard or valve. Always keep caps and guards in place and close valve when not in use.
- Gas cylinders are heavy, use mechanical lifting equipment.
- ☐ **Warning!** Failure to comply with these instructions may result in loss of load, damage to trolley or other property and/or personal injury.

2. INTRODUCTION

Robust trolley carries portable MIG welder and gas bottle, making relocation of welding equipment quick and easy. Fitted with two fixed wheels and two castors for excellent manoeuvrability and supplied with bottle retaining chains and cable stowage hooks.

Upper tray for MIG welder and two lower trays for associated items. Suitable for portable MIG welders up to 300mm wide and 480mm long.

Suitable for Sealey Welders: PMG110 and S0771. Also PM140XT, PM150XT, PMG135XT, PMG155XT with wheels and axle removed.

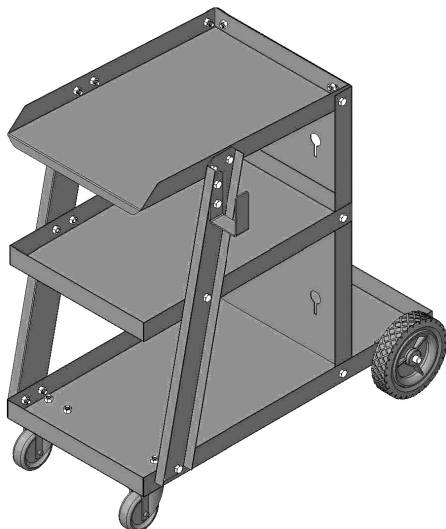

3. ASSEMBLY

- 3.1 Using the diagram below as a guide; loosely assemble the trolley.
- 3.2 Slide the axle supports (13) through the slots in the base (5) so the axle may be inserted into the supports.
- 3.3 When the wheels (12 and 6), back panel (15), shelves (1, 3 and 5), upright supports (4 and 8) and the hooks (2) are in place, tighten all fixings.

NOTE! When attaching the back panel (15) ensure the slots for the chains are facing downwards.

No.	Description	Qty.
1	Top Tray	1
2	Hook	2
3	Middle Tray	1
4	Left support	1
5	Bottom Tray	1
6	Front Castor Wheel	2
7	Hex-nut	34
8	Right Support	1
9	Hex-bolt	34
10	Split Pin	2
11	Flat Washer	4
12	Rear Wheel	2
13	Axle Support	2
14	Axle	1
15	Back Panel	1
16	Chain	2

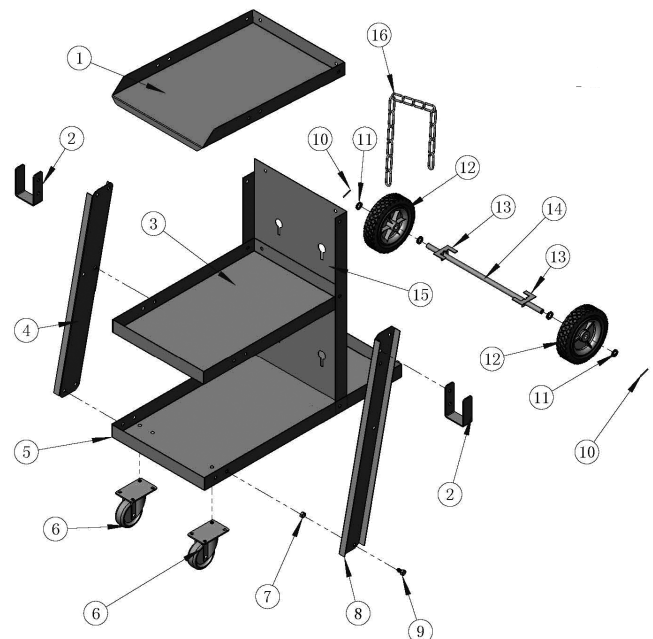

4. USING THE TROLLEY

BTR4.V2

4.1 LOADING A GAS BOTTLE

4.1.1 The trolley can be loaded with a suitable gas bottle up to a size of 93cm in height. Taller bottles should not be loaded onto the trolley as it may become unstable in transit. The maximum weight of bottle should not exceed 50kg. The trolley is designed to accommodate one bottle only.

4.1.2 Position the trolley as near as possible to the welding bottle. The maximum size bottle will require two people to load it. When the bottle is in place it should be held steady by one person whilst the other secures the chains around the bottle. The chains must be as tight as possible to ensure stability of the trolley. Make sure that the ends of the chains are fully engaged in the slots in the back of the vertical back panel.

4.2 LOADING A WELDER

4.2.1 The trolley is primarily intended for MIG welders that use gas but could equally accommodate an arc welder as long as it does not exceed the maximum footprint dimensions of 300mm wide and 480mm long.

4.2.2 Place the welder onto the top shelf and ensure that it is retained by the lipped sides. Any tall feet or wheels on the welder that prevent it sitting down properly into the tray should be removed.

4.3 MOVING A FULLY LOADED TROLLEY

4.3.1 For transit purposes the welding cables can either be coiled and placed in the lower trays or hung on the cable brackets on either side of the support rails.

4.3.2 Before moving the trolley ensure that the bottle retaining chains are tightly fastened and that there are no dangling cables that could become caught in the wheels.

4.3.3 Move the trolley by taking hold of the down turned lip at the front of the top shelf. Do not try to move the trolley by pushing or pulling on the welder or gas bottle.

4.3.4 The trolley should only be moved over smooth and level surfaces.

4.4 WELDING WITH THE TROLLEY

4.4.1 At the welding site ensure that the trolley is conveniently placed within reach of both the power socket and the item to be welded without any cables being over-stretched.

4.4.2 Do not switch the welder on whilst the cables are still stowed on the trolley.

4.4.3 **Warning!** Never attach the welder's earth clamp directly to the trolley frame as this will damage the paint finish and could result in accidental arcing from the torch.

4.4.4 Do not attempt to move the trolley by pulling on the earth or torch cable.

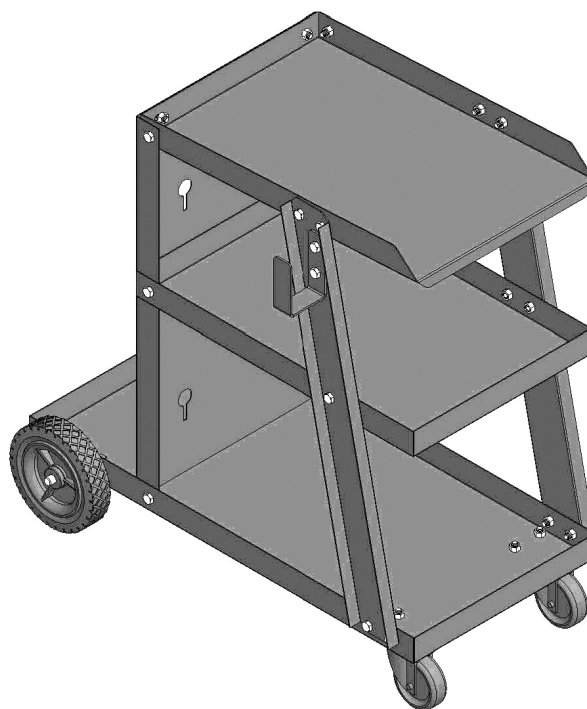

Parts support is available for this product. To obtain a parts listing and/or diagram, please log on to www.sealey.co.uk, email sales@sealey.co.uk or phone 01284 757500.

NOTE: It is our policy to continually improve products and as such we reserve the right to alter data, specifications and component parts without prior notice.



IMPORTANT: No liability is accepted for incorrect use of this product.

WARRANTY: Guarantee is 12 months from purchase date, proof of which will be required for any claim.

INFORMATION: For a copy of our catalogue and latest promotions call us on 01284 757525 and leave your full name, address and postcode.



Sole UK Distributor
Sealey Group,
Bury St. Edmunds, Suffolk.

 01284 757500
 01284 703534



www.sealey.co.uk
sales@sealey.co.uk