

# SEALEY

# Quality MACHINERY

INSTRUCTIONS FOR:

PROFESSIONAL BANDSAWS 305 & 335mm

Model Nos: **SM1305 & SM1306**

Thank you for purchasing a Sealey product. Manufactured to a high standard this product will, if used according to these instructions and properly maintained, give you years of trouble free performance.



**IMPORTANT: PLEASE READ THESE INSTRUCTIONS CAREFULLY. NOTE THE SAFE OPERATIONAL REQUIREMENTS, WARNINGS AND CAUTIONS. USE THIS PRODUCT CORRECTLY AND WITH CARE FOR THE PURPOSE FOR WHICH IT IS INTENDED. FAILURE TO DO SO MAY CAUSE DAMAGE AND/OR PERSONAL INJURY AND WILL INVALIDATE THE WARRANTY. PLEASE KEEP INSTRUCTIONS SAFE FOR FUTURE USE.**

## 1. SAFETY INSTRUCTIONS

### 1.1. ELECTRICAL SAFETY.

**WARNING!** It is the user's responsibility to read, understand and comply with the following:

You must check all electrical equipment and appliances to ensure they are safe before using. You must inspect power supply leads, plugs and all electrical connections for wear and damage. You must ensure the risk of electric shock is minimised by the installation of appropriate safety devices. An RCCB (Residual Current Circuit Breaker) should be incorporated in the main distribution board. We also recommend that an RCD (Residual Current Device) is used with all electrical products. It is particularly important to use an RCD with portable products that are plugged into an electrical supply not protected by an RCCB. If in doubt consult a qualified electrician. You may obtain a Residual Current Device by contacting your Sealey dealer. **You must** also read and understand the following instructions concerning electrical safety.

1.1.1. The **Electricity At Work Act 1989** requires all portable electrical appliances, if used on business premises, to be tested by a qualified electrician, using a Portable Appliance Tester (PAT), at least once a year.

1.1.2. The **Health & Safety at Work Act 1974** makes owners of electrical appliances responsible for the safe condition of the appliance and the safety of the appliance operator. **If in any doubt about electrical safety, contact a qualified electrician.**

1.1.3. Ensure the insulation on all cables and the product itself is safe before connecting to the mains power supply. See 1.1.1. & 1.1.2. above and use a Portable Appliance Tester (PAT).

1.1.4. Ensure that cables are always protected against short circuit and overload.

1.1.5. Regularly inspect power supply, leads, plugs for wear and damage and all electrical connections to ensure that none is loose.

1.1.6. **Important:** Ensure the voltage marked on the product is the same as the electrical power supply to be used and check that plugs are fitted with the correct capacity fuse. A 13 amp plug may require a fuse smaller than 13 amps for certain products, see fuse rating at right.

1.1.7. **DO NOT** pull or carry the powered appliance by its power supply lead.

1.1.8. **DO NOT** pull power plugs from sockets by the power cable.

1.1.9. **DO NOT** use worn or damaged leads, plugs or connections. Immediately replace or have repaired by a qualified electrician. A U.K. 3 pin plug with ASTA/BS approval is fitted. In case of damage, cut off and fit a new plug according to the following instructions (discard old plug safely).

(UK only - see diagram at right). **Ensure the unit is correctly earthed via a three-pin plug.**

a) **Connect the GREEN/YELLOW earth wire to the earth terminal 'E'.**

b) **Connect the BROWN live wire to live terminal 'L'.**

c) **Connect the BLUE neutral wire to the neutral terminal 'N'.**

b) **After wiring, check that there are no bare wires, that all wires have been correctly connected, that cable outer insulation extends beyond the cable restraint and that the restraint is tight.**

Double insulated products are fitted with live (BROWN) and neutral (BLUE) wires only. Double insulated products are always marked with this symbol . **To re-wire, connect the brown & blue wires as indicated above. DO NOT connect the brown or blue to the earth terminal.**

1.1.10. Some products require more than a 13 amp electrical supply. In such a case, **NO** plug will be fitted. **You must** contact a qualified electrician to ensure a 30 amp fused supply is available. We recommend you discuss the installation of a industrial round pin plug and socket with your electrician.

1.1.11. **Cable extension reels.** When a cable extension reel is used it should be fully unwound before connection. A cable reel with an RCD fitted is recommended since any product which is plugged into the cable reel will be protected. The section of the cores of the cable is important. We suggest 1.5mm<sup>2</sup> section as a minimum but to be absolutely sure that the capacity of the cable reel is suitable for this product and for others that may be used in the other output sockets, we recommend the use of 2.5mm<sup>2</sup> section cable.

### 1.2. GENERAL SAFETY

**WARNING!** Disconnect the saw from the mains power before changing saw blades and accessories, servicing or performing maintenance.

Mount the saw to a secure surface such as the stand supplied or a workbench. Keep area clean and tidy and free from unrelated materials and ensure there is adequate lighting.

Maintain the saw in good condition (use authorised service agent only).

Replace or repair damaged parts. *Use recommended parts only. Unauthorised parts may be dangerous and will invalidate the warranty.*

Keep the machine clean and the blade sharp for best and safest performance. Check moving parts alignment regularly.

Before each use check saw blade condition. If worn or damaged replace immediately.

Place the blade guard to within 1/8" of the material being cut.

**WARNING!** Keep all safety guards and holding screws in place, tight and in good working order. Check regularly for damaged parts. A guard or any other part that is damaged should be repaired or replaced before the saw is next used. The safety guard is a mandatory fitting.

Remove adjusting keys and wrenches from the saw before turning it on.

Wear approved safety eye protection, ear defenders, safety gloves and, if dust is generated, respiratory protection.

Remove ill fitting clothing. Remove ties, watches, rings, and other loose jewellery, and contain long hair.

Maintain correct balance and footing. Ensure the floor is not slippery and wear non-slip shoes.

Keep children and unauthorised persons away from the working area.

Secure unstable work piece with a clamp, vice or other adequate holding device.

Avoid unintentional starting.

Keep hands and fingers at a safe distance from the saw blade, especially at the end of a cut. Guide the work with a piece of wood or push rod rather than your fingers when cutting small pieces.

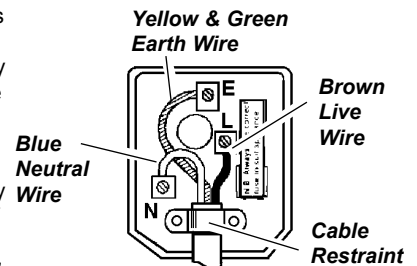

**FUSE RATING**  
**13 AMP**

## 1.2. GENERAL SAFETY Continued

- ✓ Disconnect the saw from the power supply before removing wood chips or dust.
- ✓ Use a workpiece support when sawing material which extends beyond the saw table.
- x **DO NOT** operate the machine if damaged.
- x **DO NOT** operate the machine if any parts are missing as this may cause failure and/or personal injury.
- x **DO NOT** use saw blades which are damaged or deformed. Use only Sealey blades and spare parts. Non-standard blades can be dangerous.
- x **DO NOT** get the saw wet or use in damp or wet locations or areas where there is condensation.
- x **DO NOT** expose the saw housing to flame or high temperature.
- x **DO NOT** allow untrained persons to operate the saw.
- x **DO NOT** use saw where there are flammable liquids, solids or gases such as paint solvents and including waste wipers or cleaning rags etc.
- x **DO NOT** leave the saw operating unattended.
- x **DO NOT** operate the saw if either of the blade covers is open or if the blade guard is not fitted.
- x **DO NOT** operate the saw when you are tired or under the influence of alcohol, drugs or intoxicating medication.
- x **DO NOT** use the saw for a task it is not designed to perform.
- ✓ When not in use switch off the saw and unplug from the mains power.

## 2. DESCRIPTION & SPECIFICATIONS

Fully approved to current CE regulations. Steel chassis with locking blade wheel covers. Bearing mounted blade wheels and belt drive induction motor provide smooth operation. Micro switches prevent operation when either blade wheel cover is open. No-volt release switch prevents uncontrolled blade re-start after power interruption. Suitable for cutting wood and plastics. Fitted with tilting table for bevel and compound cuts. Supplied with quick adjusting rip fence, mitre gauge, dust extraction port and sturdy metal stand.

<b>Model No:</b>	.....SM1305	.....SM1306
Throat Depth:	.....305mm	.....335mm
Max. Cutting Height:	.....180mm	.....180mm
Table Size:	.....500x400mm	.....500x400mm
Table Tilt Adjustment:	.....0-45°	.....0-45°
Blade Length:	.....2240mm	.....2400mm
Cutting Speeds:	.....360 & 660m/min	.....540 & 660m/min
Motor Power:	.....550W	.....750W
Power Supply:	.....240V - 50Hz	.....240V - 50Hz
Dust Extraction Port:	.....Ø100mm	.....Ø100mm

### MAIN FEATURES

- A** Blade tension adjustment knob
- B** Blade cover lock
- C** Blade guard height locking knob  
(additionally SM1306 has a lowering wheel for the blade guard)
- D** Blade guard
- E** Fence
- F** No Volt On/Off switch
- G** Fence lock handle
- H** Table side guide
- I** Mitre guide
- J** Blade
- K** Drive belt tensioner knob
- L** Extraction outlet
- M** Tracking adjustment knob
- N** Stand

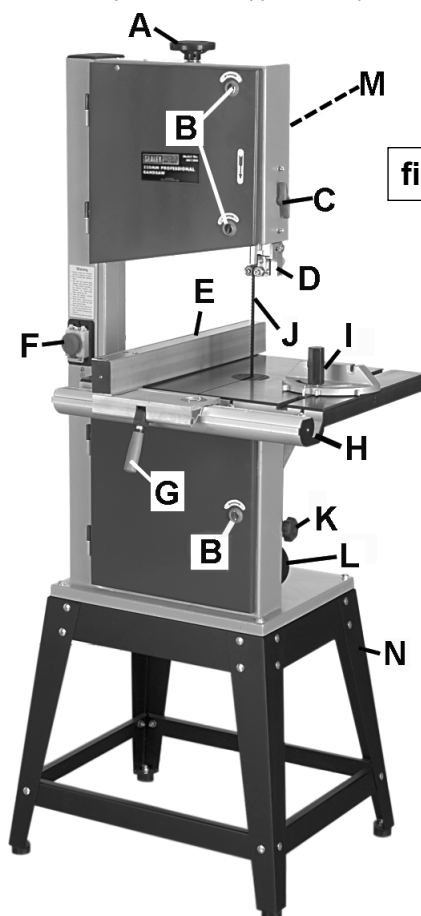
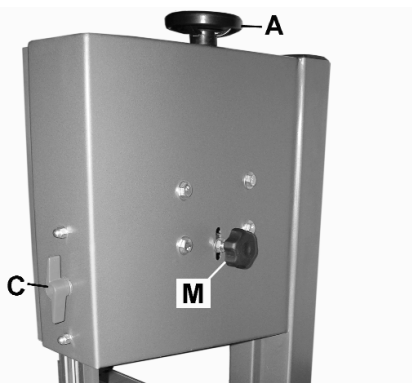

## 3. ASSEMBLY

Unpack the product and check contents for damage. Should there be any damaged or missing parts contact your supplier immediately.

### 3.1. Stand Assembly

- 3.1.1. Assemble stand as shown in fig.1.N. Ensure all fittings are tight.

### 3.2. Saw Assembly

An assistant may be required to help.

- 3.2.1. To install the table, place table and support onto the sliding base support, sliding saw blade through the slot in table, and also ensuring bolt (part 126) is in place and aligns with hole in base support.
- 3.2.2. Secure by threading adjustment knob onto bolt and tightening.
- 3.2.3. Fit the bolt into the blade slot of table. Attach the table side guide to the table with four bolts and washers.
- 3.2.4. Fit the fence, first align bearing at the far end with one of the table slots, then lower onto table side guide. Push down handle (fig.1.G) to lock when fence is in required position.
- 3.2.5. Position table at right angles to the blade. Using a set square against the blade check for accuracy. If any adjustment is needed, loosen nuts and bolts holding the sliding base support and make any necessary fine adjustments. Tighten all nuts and bolts.
- 3.2.6. **Important!** Attach the saw to the stand using appropriate bolts, nuts and washers, or alternatively to a firm, stable work surface capable of supporting the saw and any workpiece.  
**DO NOT** attempt to use the saw as a free-standing unit as it may topple over during use and cause damage and/or personal injury.
- 3.2.7. Connect extraction port (Ø100mm) to dust extractor system (if available).

## 4. ADJUSTMENTS

**WARNING! ENSURE THAT THE BANDSAW IS DISCONNECTED FROM THE POWER SUPPLY BEFORE ATTEMPTING ANY ADJUSTMENTS.**

### 4.1. Changing the blade

- 4.1.1. Turn the blade cover locks (fig.1.B) anticlockwise to open the upper and lower covers.
- 4.1.2. Turn blade tension adjustment knob anticlockwise (fig.1.A) to slacken the blade.
- 4.1.3. Remove the table side guide and the securing bolt from the table blade slot.
- 4.1.4. Carefully remove the blade.
- 4.1.5. Install the new blade. Be sure the teeth are pointing downwards and outwards. Refit securing bolt and table side guide.
- 4.1.6. Adjust new blade to the correct tension (see 4.2.) and check, and adjust if necessary, tracking (see 4.3.) and blade guide adjustment (see 4.5.).
- 4.1.7. Close both blade covers and lock with blade cover locks.

### 4.2. Adjusting blade tension

- 4.2.1. Open the blade covers and check to ensure that blade is centred on both wheel rims (if not, see section 4.3).
- 4.2.2. Turn the blade tension knob (fig.1.A) to adjust the blade tension - clockwise to tighten, anticlockwise to slacken. Correct tension is reached when the blade gives slightly to firm finger pressure at mid-span. Do not over-tighten.
- 4.2.3. Close both blade covers and lock with blade cover locks.

### 4.3. Adjusting blade tracking

- 4.3.1. Open blade covers and carefully rotate the upper blade wheel (fig.3) clockwise by hand, to determine whether blade is tracking correctly - blade should be on the centre of each wheel rim.
- 4.3.2. If adjustment is needed, turn the tracking knob (fig.2.M) whilst continuing to turn the upper blade wheel. Note the effect on the tracking and continue to turn tracking knob until tracking is correct.
- 4.3.3. Close both blade covers and lock with blade cover locks.

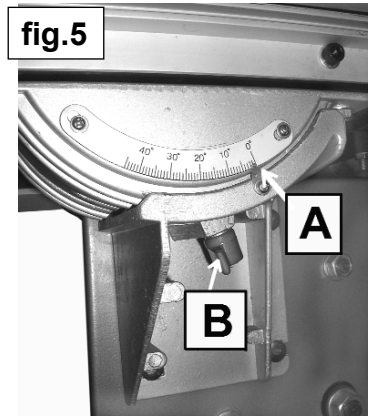
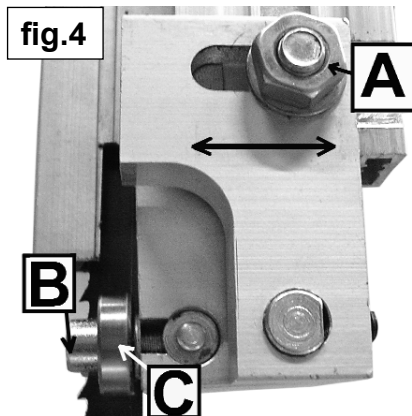
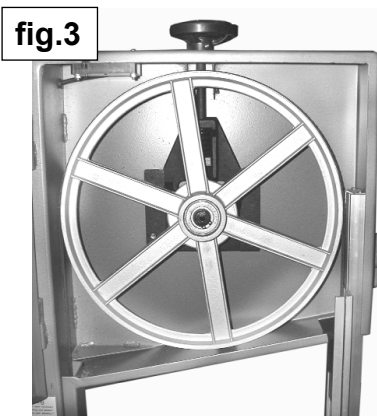

### 4.4. Upper blade guide position

- 4.4.1. The upper blade guide should always be adjusted to about 3mm above the workpiece. To adjust, loosen the locking knob (fig.1.C) and lower the assembly to the required position (SM1306 also has a lowering wheel). Tighten locking knob.

### 4.5. Upper blade guide bearing adjustment

- 4.5.1. The upper blade guide support bearing prevents the saw blade from being pushed too far back when cutting. It should be adjusted to 0.75mm behind the blade. Loosen nut (fig.4.A) and by sliding the bearing holder left or right, position the bearing correctly and then tighten the nut to secure. Re-check for correct positioning.
- 4.5.2. The upper blade guide side bearings prevent the saw blade from being pushed sideways when cutting. Adjust the bearings (fig.4.C) so that each is just clear of the blade. Loosen the allen bolts (fig.4.B) and slide the bearings to position them correctly. Tighten allen bolt to secure. Re-check for correct positioning.

### 4.6. Lower blade guide bearing adjustment

- 4.6.1. The three lower guide bearings should be adjusted using the same procedure as for the upper guide bearings above. They are positioned within the lower blade cover.
- 4.6.2. All three bearings are held in place by allen bolts. Position each bearing correctly and re-check for correct positioning after tightening the allen bolts.

- Notes:
- a) Always check and adjust both upper and lower guides at the same time.
  - b) Carry out these checks/adjustments every time the blade is changed.
  - c) The blade will be damaged if the teeth contact the guides/guide bearings.

### 4.7. Drive belt tension

- 4.7.1. Open lower blade cover and check belt tension. Belt should have approx. 5mm mid-span deflection under finger pressure.
- 4.7.2. To adjust belt tension turn drive belt tensioner knob (fig.1.K) until correct tension is achieved. Close and lock cover.

### 4.8. Blade speed

- 4.8.1. Open lower blade cover and remove all belt tension by turning belt tensioner knob anticlockwise (fig.1.K).
- 4.8.2. Move belt to the required pair of pulleys (see fig.6. for required blade speeds).
- 4.8.3. Tension belt correctly (see 4.7.) by turning drive belt tensioner knob (fig.1.K) and close and lock cover.

### 4.9. Mitre gauge

- 4.9.1. The mitre gauge (fig.1.I), which can be located in either of the two table slots, is adjustable through 45° in either direction. Loosen the central locking knob, adjust and then tighten locking knob.

### 4.10. Table Angle

- 4.10.1. Loosen the knob (fig.5.A) and adjust table to required angle using the scale (fig.5.B) as a guide. Tighten knob when in required position.

fig.6

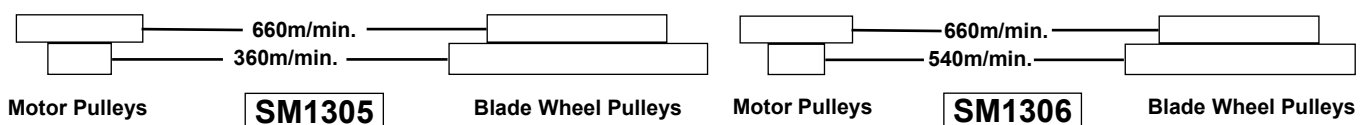

#### 4.11. Fence

4.11.1. The fence (fig.1.E) is mounted on the table side guide (fig.1.H).

4.11.2. To reposition or remove the fence, push up locking handle (fig.1.G). To refit the fence, first align bearing at it's far end with one of the table slots, then lower onto table side guide. Push down handle (fig.1.G) to lock when fence is in required position.

### 5. OPERATING INSTRUCTIONS

To switch saw on, lift the No Volt switch cover and press the on switch. Switch cover should be lowered over on/off switch. Simply hit the No Volt switch to turn saw off. If saw does not switch on, ensure both blade cover doors are shut and secured.

Adjust blade guide to just above the workpiece (3mm). Use both hands to feed workpiece to the blade. Use a steady even pressure sufficient to keep blade cutting but no more. If needed, stop the saw and wait for blade to stop before backing blade out of a cut.

#### 5.1. Rip sawing

Cutting wood with the grain. For best results use rip fence on left side of saw to guide workpiece. The table side guide scale shows the distance between the blade and the right hand edge of the workpiece.

#### 5.2. Cross cutting

To cut wood at right angles to the grain. This type of cut can be made freehand but using the mitre guide ensures accurate results. The guide can also be adjusted up to a 45° angle to produce mitre cuts or compound cuts with the table tilted. Ensure the work is held firmly against the table and against the face of the mitre guide.

**WARNING!** Keep your fingers away from the blade, use an offcut piece of wood to push the last piece of work through.

#### 5.3. Freehand

When freehand cutting, always feed the work slowly to follow your saw line. Ensure you do not drag the work off-line forcing the blade sideways or twisting it. It may be helpful to make an initial rough cut about 5mm away from the line. For difficult curves which may be too tight for the blade, make relief cuts on the face of the curve so that the waste wood will fall away as the final radius is cut.

#### 5.4. Blade and blade speed selection

5.4.1. The hardness of the workpiece determines the blade speed required. Soft materials - high speed, hard materials- low speed.

5.4.2. There should be at least three saw teeth in contact with the workpiece at any one time during cutting. Therefore the thinner the workpiece the higher the blade tpi required.

#### 5.5. Bevel cutting

When bevel cutting with the table tilted always have the workpiece guide (fence or mitre) on the lower part of the table.

#### 5.6. Workpiece stability

Any workpiece which does not have a flat surface which will ensure stability on the saw table **must be** held in a suitable device which will prevent rotation.

### 6. MAINTENANCE

**WARNING! ENSURE THE MACHINE IS DISCONNECTED FROM THE MAINS POWER SUPPLY BEFORE CARRYING OUT ANY MAINTENANCE.**

#### 6.1. Changing belts

Eventually the rubber belts on the bandsaw wheels will wear due to the constant contact with the blade teeth.

Remove blade (see 4.1), lift the edge of the belt (item 19) with a small screwdriver and the belt can be worked off the wheel easily. It is recommended that both belts be changed at the same time.

#### 6.2. Blades

If blades break, check for correct tension after fitting new blade. Also avoid over working blade by keeping to a constant feed rate and avoiding any side pressure on the blade.

#### 6.3. Blade guides

Blade guides should be inspected regularly for wear or chipping. When replacing guides, replace all guides at the same time, both upper and lower.

#### 6.4. Table insert

The insert should be inspected regularly and replaced if wear or damage is found.

#### 6.5. Bearings

All bearings used in the construction of the bandsaw and motor are sealed and lubricated for life.

#### 6.6. Cleaning

Remove dust and chips from the inside of the bandsaw frequently. Open the wheel covers and use a brush or vacuum cleaner. At the end of every work session, clean sawdust away from the motor vents.

### 7. DECLARATION OF CONFORMITY

**Declaration of Conformity** We, the sole importer into the UK, declare that the products listed here are in conformity with the following standards and directives.

#### Professional Bandsaws

Model Nos: SM1305, SM1306

73/23/EEC Low Voltage Directive

98/37/EC Machinery Directive

89/336/EEC EMC Directive

93/68/EEC CE Marking Directive.



The construction files for these products are held by the manufacturer and may be inspected, by a national authority, upon request to Jack Sealey Ltd.

Signed by Steve Buckle

23rd May 2006

For Jack Sealey Ltd. Sole importer into the UK of Sealey Quality Machinery.

**NOTE:** It is our policy to continually improve products and as such we reserve the right to alter data, specifications and component parts without prior notice.

**IMPORTANT:** No liability is accepted for incorrect use of this equipment.

**WARRANTY:** Guarantee is 12 months from purchase date, proof of which will be required for any claim.

**INFORMATION:** For a copy of our latest catalogue and promotions call us on 01284 757525 and leave your full name and address, including postcode.



Sole UK Distributor  
Sealey Group,  
Bury St. Edmunds, Suffolk.



01284 757500



01284 703534



[www.sealey.co.uk](http://www.sealey.co.uk)



[sales@sealey.co.uk](mailto:sales@sealey.co.uk)