

INSTRUCTIONS FOR: WHEEL BEARING REMOVAL / INSTALLATION KIT

MODEL No: **VS7020.V2**

1. SAFETY INSTRUCTIONS

- ❑ **WARNING!** Ensure all Health and Safety, local authority, and general workshop practice regulations are strictly adhered to when using tools.
- ✗ **DO NOT** use tools if damaged or worn.
- ✓ Maintain the tools in good and clean condition for best and safest performance.
- ✓ Ensure all threads are clean and well lubricated.
- ✓ Ensure vehicle is adequately supported with axle stands, ramps, etc. as appropriate.
- ✓ Wear suitable clothing to avoid snagging. Do not wear jewellery. Tie back long hair.
- ✓ Wear approved eye protection. A full range of personal safety equipment is available from your Sealey dealer.
- ✓ Account for all tools and parts being used and do not leave them in or on the vehicle.

IMPORTANT: Always refer to the vehicle manufacturer's service instructions, or proprietary manual, to establish the correct procedure and data for the specific vehicle you are working on. These instructions for use are provided as a guide only.

2. INTRODUCTION

Comprehensive kit of tools for the fast and effective removal and installation of wheel bearings on front-wheel drive vehicles. Reduces chances of damage to hub and bearing. Heavy-duty steel drifts with phosphate coating to prevent corrosion. Heavy-weight drive screw for use with impact tools. Also suitable for removing and installing large industrial bearings. Supplied in carry-case.

3. SPECIFICATIONS

Model No:	VS7020.V2
Drift Sizes Ø:	50, 55, 60, 64, 67, 73, 75, 78, 82, 84, 88mm
Sleeve Ø External:	76, 86, 92, 101mm
Hub screw length:	210mm
Hub screw drive:	32, 38mm

- | | |
|------------------|----------------|
| 1. HUB SCREW NUT | 5. VEHICLE HUB |
| 2. WASHER | 6. SLEEVE |
| 3. DRIFTS | 7. SLEEVE CAP |
| 4. BEARING | 8. HUB SCREW |

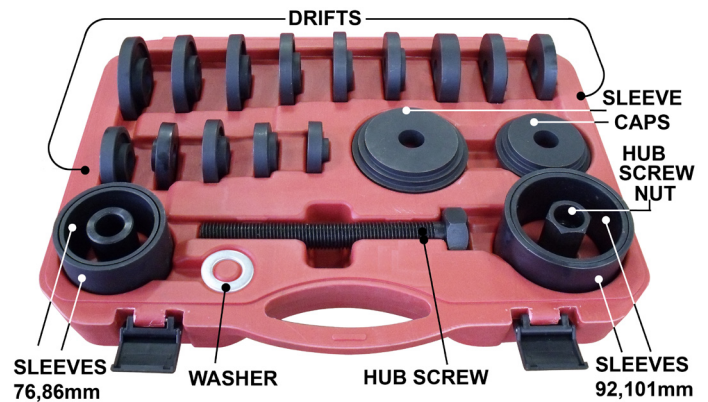

4. INSTRUCTIONS

BEARING REMOVAL: Identify the correct sleeve (6) to sit on the outside of the bearing housing and the correct drift (3) to drive the bearing from the housing. Assemble as shown in fig.1A using the correct sleeve cap (7). Keep the hub screw and nut well lubricated whilst driving out the bearing.

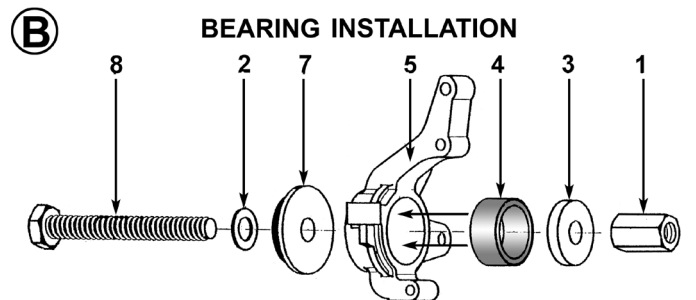
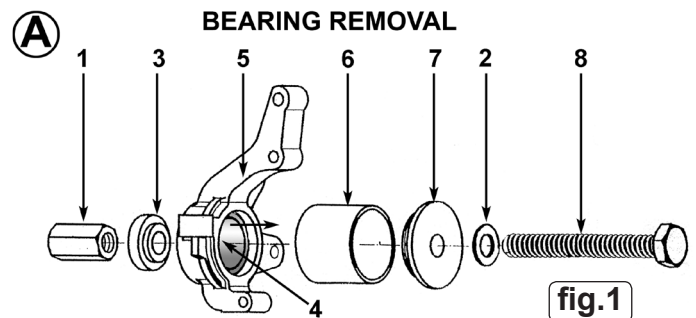

BEARING INSTALLATION: Identify the correct sleeve cap (7) to sit on the outside of the bearing housing and the correct diameter drift (3) to drive the new bearing into the housing. Assemble as shown in fig.1B. Keep the hub screw and nut well lubricated whilst driving the new bearing into the housing.

Parts support is available for this product. To obtain a parts listing and/or diagram, please log on to www.sealey.co.uk, email sales@sealey.co.uk or phone 01284 757500.

NOTE: It is our policy to continually improve products and as such we reserve the right to alter data, specifications and component parts without prior notice.

IMPORTANT: No liability is accepted for incorrect use of this product.

WARRANTY: Guarantee is 12 months from purchase date, proof of which will be required for any claim.

INFORMATION: For a copy of our latest catalogue and promotions call us on 01284 757525 and leave your full name and address, including postcode.