

Thank you for purchasing a Sealey product. Manufactured to a high standard this product will, if used according to these instructions and properly maintained, give you years of trouble free performance.

 **IMPORTANT: PLEASE READ THESE INSTRUCTIONS CAREFULLY. NOTE THE SAFE OPERATIONAL REQUIREMENTS, WARNINGS, AND CAUTIONS. USE THIS PRODUCT CORRECTLY, AND WITH CARE FOR THE PURPOSE FOR WHICH IT IS INTENDED. FAILURE TO DO SO MAY CAUSE DAMAGE AND/OR PERSONAL INJURY AND WILL INVALIDATE THE WARRANTY.**

## 1. SAFETY INSTRUCTIONS

- WARNING!** *Ensure Health & Safety, local authority and general workshop practice regulations are adhered to when using this equipment.*
- WARNING!** Disconnect the hammer from the air supply before changing accessories, servicing or performing any maintenance.
- ✓ Keep the hammer clean and maintain it in good condition.
- ✓ Replace or repair damaged parts. *Use genuine parts only. Unauthorised parts may be dangerous and will invalidate the warranty (use an authorised service agent).*
- ✓ Keep the work area clean and uncluttered. Ensure that there is adequate lighting.
- ✓ Ensure chisels are correctly rated for the job. **DO NOT** use damaged or suspect chisels.
- WARNING!** Wear approved safety eye or face protection, ear defenders and, if dust is generated, respiratory protection.
- ✓ Keep hands and body clear of the work when operating the hammer.
- ✓ Maintain correct balance and footing. Ensure that the floor is not slippery and wear non-slip shoes.
- ✓ Remove ill fitting clothing. Remove ties, watches, rings and other loose jewellery and contain and/or tie back long hair.
- ✓ Keep children and unauthorised persons away from the work area.
- ✓ Secure unstable workpiece with a clamp, vice or other adequate holding device.
- ✓ Avoid unintentional starting.
- WARNING!** Ensure that the correct air pressure is maintained and not exceeded.
- ✓ Keep air hose away from heat, oil and sharp edges. Check air hose for wear before each use and ensure that all connections are secure.
- ✓ **DO NOT** use the hammer for a task it is not designed to perform.
- ✗ **DO NOT** operate the hammer if any parts are damaged or missing as this may cause failure and/or personal injury.
- WARNING!** **DO NOT** chisel into any materials containing asbestos.
- ✗ **DO NOT** switch the hammer on whilst the chisel is in contact with the workpiece.
- ✗ **DO NOT** carry by the hose, or yank the hose from the air supply.
- ✗ **DO NOT** hold the workpiece by hand. Use clamps or a vice (not included) to secure the workpiece. Available from your Sealey dealer.
- ✗ **DO NOT** allow untrained persons to operate the hammer.
- ✗ **DO NOT** operate the hammer when you are tired or under the influence of alcohol, drugs or intoxicating medication.
- ✗ **DO NOT** use hammer where there is flammable liquid, solid or gas such as paint solvent, including waste wiping or cleaning rags etc.
- ✗ **DO NOT** leave the hammer operating unattended.
- ✗ **DO NOT** carry the hammer with your finger on the trigger.
- ✗ **DO NOT** direct air from the air hose at yourself or others.
- ✓ When work is complete ensure that the air supply is turned off.

**Risk of Hand Arm Vibration Injury**  
 Medium Stroke G3 Air Hammer Model No. GSA12 when operated in accordance with these instructions and tested in accordance with EN 28662-2: 1994 results in the following vibration emission declared in accordance with BS EN12096: 1996.  
 Measured vibration emission value: .....20m/s<sup>2</sup> Uncertainty: .....8m/s<sup>2</sup>  
**These values are suitable for comparison with emission levels of other tools that have been subject to the same test.**  
**This tool may cause hand-arm vibration syndrome if its use is inadequately managed.**  
**Recommended Measures to reduce risk of hand-arm vibration syndrome:**  
 This tool should not be used by an individual regularly for more than 15.3 minutes in any 8 hour period.  
 This duration of use should be reduced if the individual is exposed to hand-arm vibration from other sources.

## 2. INTRODUCTION & SPECIFICATION

Sealey's Generation or G3 series of air tools represents some of the best design innovations in air tools of recent date. The tools feature contoured, soft-grip handles and housings which help reduce the effects of vibration and chill – major contributors to circulatory and nerve problems such as white finger. The tools also include exhaust systems designed to reduce noise levels by baffling the noise or directing it away from the operator's environment. Most of the tools include integral and adjustable air control valves for precise control of output. The air wrenches are, pound for pound, amongst the most powerful machines we have seen in the market and the materials and manufacturing techniques used in the production of all the G3 series will ensure long and reliable service.

Chisel Shank Size: .....0.401" Parker Taper	Operating Pressure: .....90psi
Speed: .....4300bpm	Air Inlet Size: .....1/4" BSP
Air Consumption: .....5cfm	Weight: .....2.2kg

## 3. AIR SUPPLY

- 3.1 Air Supply**  
 Recommended hook-up procedure is shown in fig 1.
- 3.1.1 Ensure tool air valve (or trigger) is in "off" position before connecting to the air supply.
  - 3.1.2 You will require an air pressure of 90psi, and an air flow according to specification.
  - 3.1.3  **WARNING!** Ensure the air supply is clean and does not exceed 90psi while operating the tool. Too high an air pressure and unclean air will shorten the product life due to excessive wear, and may be dangerous causing damage and/or personal injury.
  - 3.1.4 Drain the compressor air tank daily. Water in the air line will damage the tool.
  - 3.1.5 Clean compressor air inlet filter weekly.
  - 3.1.6 Line pressure should be increased to compensate for unusually long air hoses (over 8 metres). The minimum hose diameter should be 1/4" I.D. and fittings must have the same inside dimensions.
  - 3.1.7 Keep hose away from heat, oil and sharp edges. Check hose for wear, and make certain that all connections are secure.
- 3.2 Couplings.**  
 Vibration may cause failure if a quick change coupling is connected directly to the tool.  
 To overcome this, connect a leader hose to the tool. A quick change coupling may then be used to connect the leader hose to the air line recoil hose. See fig 1 & 2 (overleaf).

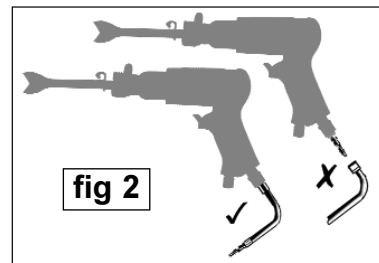
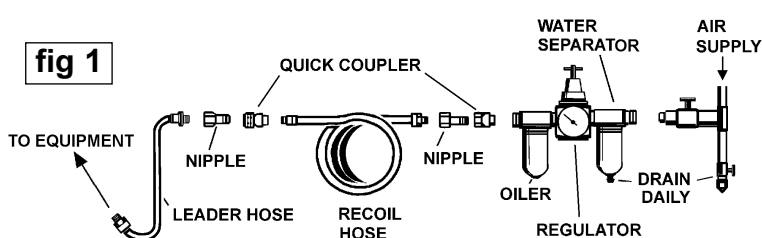

## 4. OPERATING INSTRUCTIONS

**Note:** Numbers in brackets refer to item numbers in the parts list.

The air hammer is designed primarily for use on vehicle bodywork. We do not recommend any other use. Ensure you read, understand and follow the safety instructions in Section 1.

- 4.1 Attach the retaining spring (20) by screwing it onto the cylinder (18).
- 4.2 Insert the chisel using the hooked end of the spring to hold the chisel in place.
- 4.3 Attached the tool to the air supply (see Section 3).
- 4.4 To operate the hammer, squeeze the trigger (11).

## 5. MAINTENANCE

**WARNING!** Disconnect the hammer from the air supply before changing chisels, servicing or performing any maintenance.

- 5.1 **Keep the hammer oiled for optimum performance.** Lubricate with a good grade of air tool oil such as Sealey ATO/500 or ATO/1000. If there is no oil in the air system then a teaspoon of oil can be poured into the air inlet of the hammer, or into the hose at the nearest connection to the air supply. Then run the hammer for a short time.

**Note:** The following external factors may cause loss of power and effect hammer performance:

**The air supply:** reduced compressor output, excessive drain on the air line, moisture or restrictions in air pipes or the use of hose connectors having too small a bore. Correct as necessary.

**The hammer:** grit or gum deposits in the tool. Correct by cleaning the air strainer and flushing out the tool with gum solvent oil or an equal mixture of SAE No.10 oil and kerosene. If, despite taking action as above, the tool function is still impaired, contact your local Sealey service agent.

## 6. PARTS LIST

ITEM	PART NO.	DESCRIPTION
01.	GSA11.01	HOUSING
02.	GSA01.05	SPRING PIN
03.	GSA01.08	VALVE SEAT
04.	GSA01.09	THROTTLE VALVE
05.	GSA11.05	VALVE SPRING
06.	GSA11.06	EXHAUST DEFLECTOR
07.	GSA01.12	AIR INLET
08.	GSA11.08	PLASTIC GRIP
09.	GSA11.09	BUSHING
10.	GSA11.10	TRIGGER SHAFT
11.	GSA01.06	TRIGGER
12.	GSA11.12	REAR VALVE SEAT
13.	GSA11.13	CHECK VALVE
14.	GSA11.14	VALVE PIN (A)
15.	GSA11.15	PIN
16.	GSA11.16	UPPER VALVE
17.	GSA11.17	PISTON
18.	GSA12.18	ROUND CYLINDER
19.	GSA11.19	PLASTIC COVER
20.	GSA11.20	SPRING RETAINER

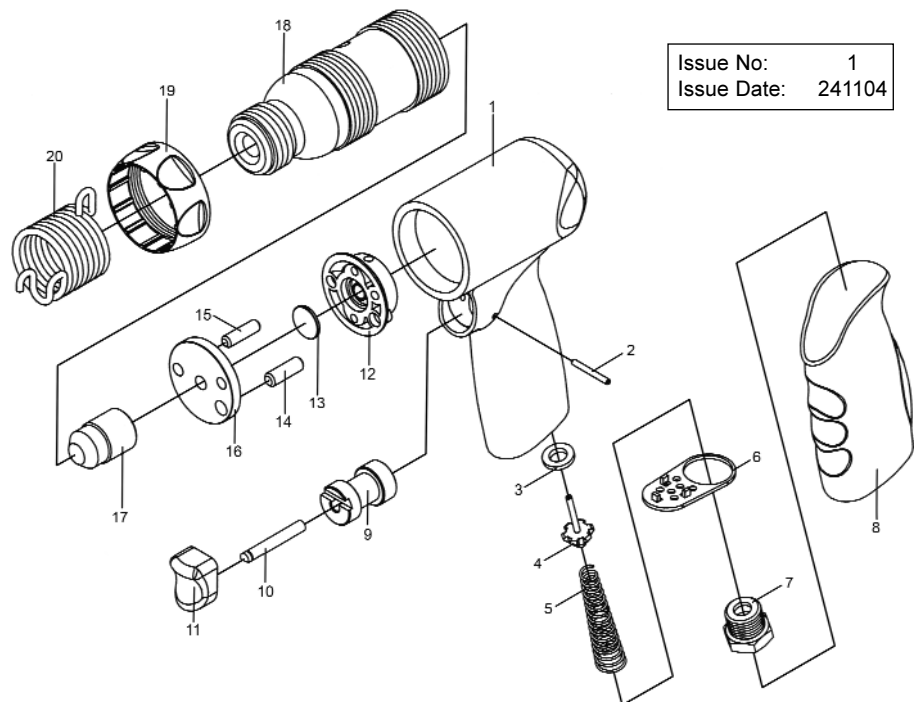

**NOTE:** It is our policy to continually improve products and as such we reserve the right to alter data, specifications and component parts without prior notice. **IMPORTANT:** No liability is accepted for incorrect use of this equipment. **WARRANTY:** Guarantee is 12 months from purchase date, proof of which will be required for any claim. **INFORMATION:** For a copy of our latest catalogue and promotions call us on 01284 757525 and leave your full name and address, including postcode.

**Declaration of Conformity** We, the sole importer into the UK, declare that the product listed here is in conformity with the following standards and directives.

**MEDIUM STROKE G3 AIR HAMMER**  
**Model: GSA12**  
 98/37/EC Machinery Directive  
 93/68/EEC CE Marking Directive



The construction file for this product is held by the Manufacturer and may be inspected, by a national authority, upon request to Jack Sealey Ltd.

Signed by Mark Sweetman

24th November 2004

For Jack Sealey Ltd.  
 Sole importer into the UK  
 of Sealey Power Products

**SEALEY POWER TOOLS**

Sole UK Distributor, Sealey Group, Bury St. Edmunds, Suffolk.



01284 757500



01284 703534



www.sealey.co.uk



sales@sealey.co.uk