

Thank you for purchasing a Sealey product. Manufactured to a high standard this product will, if used according to these instructions and properly maintained, give you years of trouble free performance.



IMPORTANT: PLEASE READ THESE INSTRUCTIONS CAREFULLY. NOTE THE SAFE OPERATIONAL REQUIREMENTS, WARNINGS & CAUTIONS. USE THE PRODUCT CORRECTLY AND WITH CARE FOR THE PURPOSE FOR WHICH IT IS INTENDED. FAILURE TO DO SO MAY CAUSE DAMAGE AND/OR PERSONAL INJURY, AND WILL INVALIDATE THE WARRANTY. PLEASE KEEP INSTRUCTIONS SAFE FOR FUTURE USE.

1. SAFETY INSTRUCTIONS

1.1 GENERAL SAFETY

- ❑ **WARNING!** Ensure Health & Safety, local authority, and general workshop practice regulations are adhered to when using this trolley.
- ✓ Always load evenly with the centre of gravity of the load as near the centre of the trolley as possible.
- ✗ **DO NOT** overload the trolley - see 2. DESCRIPTION.
- ✓ Use the trolley in a suitable work area.
- ✓ Keep the work area clean, uncluttered and ensure there is adequate lighting.
- ✓ Keep the trolley clean and tidy in accordance with good workshop practice.
- ✗ **DO NOT** use the trolley for any purpose other than that for which it is designed.
- ✗ **DO NOT** stand on the trolley, use it as a ladder or allow others to ride it.
- ✗ **DO NOT** leave unattended, especially when loaded, unless the wheels are chocked or the trolley otherwise secured.
- ✗ **DO NOT** use trolley on uneven ground and do not run over curbs or steps - use a ramp.
- ✗ **DO NOT** use trolley if any part is significantly damaged, paying particular attention to the wheels.
- ✓ Keep children and unauthorised persons away from the work area.

2. DESCRIPTION

Garage or workshop trolley with each shelf having a capacity of 80kg. Deep-walled shelves, each of which may be installed base down or base up to give either tool and component security or unobstructed access. Fitted with four large castors, two with a brake.

3. CONTENTS

Carefully unpack the product and check the contents, fig.A. Should any items be missing or damaged contact your Sealey dealer.

4. ASSEMBLY

- 4.1 Where each upright makes contact with the trays it is fixed in place with four M6 bolts passed through the holes in the tray from the inside as shown in fig.B. Each bolt is then fixed with a washer and a dome nut on the outside surfaces of the uprights.
- 4.2 Note that the uprights are handed, two left-hand and two right-hand. On each upright one face is slightly narrower than the other and has the holes 4mm closer to the corner than the longer face. The narrower face should be positioned onto the ends of the trays. See fig.B. Double check that the bolt holes in the uprights and trays are aligned on each corner during assembly.
- 4.3 Assemble the trolley as if it were on its side. See fig.C. Identify the base tray which has holes in its bottom surface for mounting the wheels and castors. Attach two uprights to the longer side of the tray leaving the dome nuts finger tight. Attach the top tray to the other ends of the uprights. If you have a 3 shelf trolley now attach the centre shelf.
- 4.4 Turn the assembly over so that the uprights are on the ground and the trays are protruding upwards. Attach the other two uprights leaving the dome nuts finger tight. See fig.C.
- 4.5 Stand the assembly on the base tray. Slide the tubular handle into each handle support and fix the handle assembly to one end of the top tray using the general assembly bolts as shown in fig.D.
- 4.6 Tighten all fixings. Hold each bolt stationary with a Phillips or slotted screw driver and tighten each dome nut with a 10mm spanner.
- 4.7 Turn the trolley upside down and bolt the two castors to the base tray at the same end of the trolley as the handle. Pass the 8mm mounting bolts through the tray from the inside surface and through the mounting plate as shown in fig.E. Drop a split washer over each bolt and fix with an 8mm Nylok nut. Mount the fixed wheels at the other end of the tray in the same manner. See fig.F.
- 4.8 Turn the assembled trolley the right way up. See fig.G.

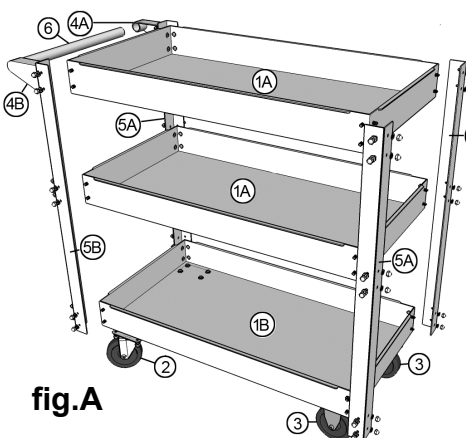

CONTENTS	
1A	Upper tray CX105 (1) CX108 (2)
1B	Base tray 1
2	Castor wheel 2
3	Fixed wheel 2
4A	Handle bracket (left-hand) 1
4B	Handle bracket (right-hand) 1
5A	Upright (left-hand) 2
5B	Upright (right-hand) 2
6	Handle tube 1
7	8mm nylock nut 16
8	6mm washer (CX105 32) 48
9	8mm wheel mounting bolt 16
10	6mm bolt (CX105 32) 48
11	8mm split washer 16
12	6mm dome nut (CX105 32) 48

fig.A

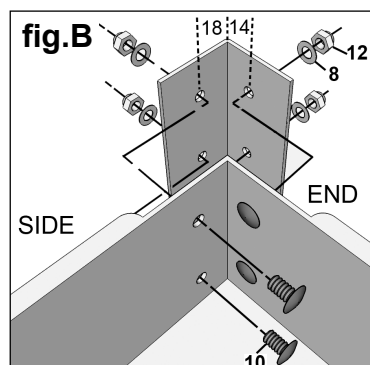

fig.B

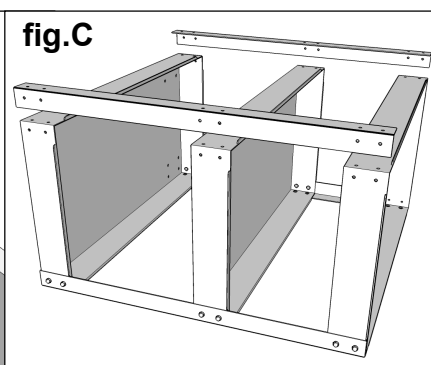

fig.C

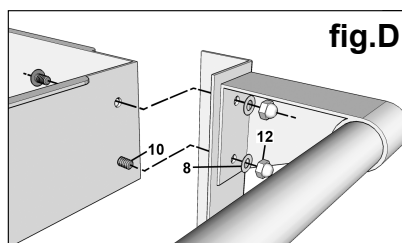

fig.D

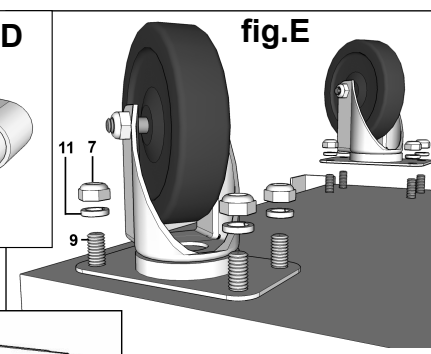

fig.E

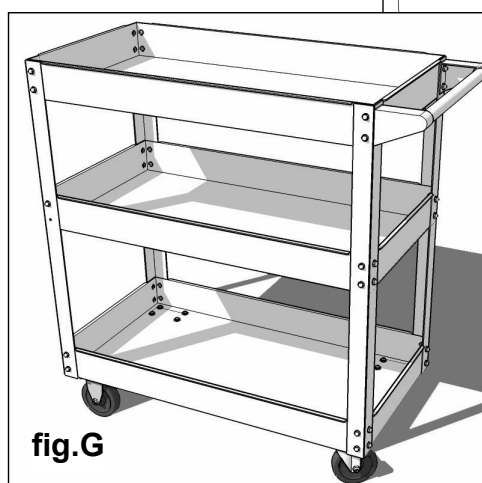

fig.G

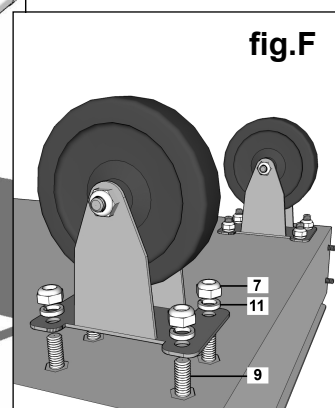

fig.F

NOTE: It is our policy to continually improve products and as such we reserve the right to alter data, specifications and component parts without prior notice. IMPORTANT: No liability is accepted for incorrect use of product. WARRANTY: Guarantee is 12 months from purchase date, proof of which will be required for any claim. INFORMATION: For a copy of our latest catalogue and promotions call us on 01284 757525 and leave your full name and address, including postcode.