



SPARE PARTS LISTING SHEET FOR

350W 230V Mill/Drill Machine

Stock No.34023

Part No.MILL-170

KEY No.	PART No.	STOCK No.	DESCRIPTION
1	YMILL-170-01	34023	Base
2	YMILL-170-02	39281	X-axis feeding screw
2-1	YMILL-170-02-1	39282	Key 4*16
3	YMILL-170-03	39283	Rivet 2*4
4	YMILL-170-04	39284	Collar
5	YMILL-170-05	39285	Handlewheel
6	YMILL-170-06	39286	Nut M8
7	YMILL-170-07	39287	Knob
8	YMILL-170-08	39288	Screw M8*55
9	YMILL-170-09	39289	Screw M6*8 8
10	YMILL-170-10	39280	Holding plate (I)
11	YMILL-170-11	39291	Dust guard cover
12	YMILL-170-12	39292	Holding plate (II)
13	YMILL-170-13	39293	Ball bearing
14	YMILL-170-14	39294	Washer
15	YMILL-170-15	39295	Nut M8
16	YMILL-170-16	39296	Y-axis ruler
17	YMILL-170-17	39297	Screw M6*16
18	YMILL-170-18	39298	Y-axis bearing seat
19	YMILL-170-19	39299	Working table
20	YMILL-170-20	39300	Y-axis feeding screw
21	YMILL-170-21	39301	End cover
22	YMILL-170-22	39302	Cap screw M6*10
23	YMILL-170-23	39303	Y-axis screw nut
24	YMILL-170-24	39304	Holding plate 3
25	YMILL-170-25	39305	Dust guard cover
26	YMILL-170-26	39306	Screw seat
27	YMILL-170-27	39307	Screw M6*16
28	YMILL-170-28	39308	Screw M6*22
29	YMILL-170-29	39309	Nut M6
30	YMILL-170-30	39310	Handle
31	YMILL-170-31	39311	Screw M6*10
32	YMILL-170-32	39312	Guide finger
33	YMILL-170-33	39313	Screw M6*5
34	YMILL-170-34	39314	X-axis wedge
35	YMILL-170-35	39315	Saddle
36	YMILL-170-36	39316	Y-Axis wedge
37	YMILL-170-37	39317	X-axis screw nut
38	YMILL-170-38	39318	Screw M6*25
39	YMILL-170-39	39319	Fuselage seat
39-1	YMILL-170-39-1	39320	Shaft
39-2	YMILL-170-39-2	39321	Key 8*12
40	YMILL-170-40	39322	Spring washer

KEY No.	PART No.	STOCK No.	DESCRIPTION
40-1	YMILL-170-40-1	39323	Washer
41	YMILL-170-41	39324	Cap screw M10*30
42	YMILL-170-42	39325	Guide finger
43	YMILL-170-43	39326	Screw M6*20
44	YMILL-170-44	39327	Ruler
45	YMILL-170-45	39328	Wedge
46	YMILL-170-46	39329	Gear rack
47	YMILL-170-47	39330	Cap screw M6*12
48	YMILL-170-48	-	Label
49	YMILL-170-49	39331	Spindle box
50	YMILL-170-50	39332	Pinion
51	YMILL-170-51	39333	Key 4*20
52	YMILL-170-52	39334	Bevel gear
53	YMILL-170-53	39335	Check ring
54	YMILL-170-54	39336	Steel ball
55	YMILL-170-55	39337	Spring
56	YMILL-170-56	39338	Screw M6*8
57	YMILL-170-57	39339	Handle stock
58	YMILL-170-58	39340	Operating lever
59	YMILL-170-59	39341	Lever cap
60	YMILL-170-60	39342	Cap screw M8*45
61	YMILL-170-61	39343	Guide finger
62	YMILL-170-62	39344	Screw M6*25
63	YMILL-170-63	39345	Spindle box seat
64	YMILL-170-64	39346	Wedge
65	YMILL-170-65	39347	Limit Block
66	YMILL-170-66	39348	Small wedge
67	YMILL-170-67	39349	Ruler
68	YMILL-170-68	39350	Fuselage
69	YMILL-170-69	39351	Electrical box
70	YMILL-170-70	39352	Nut M24
71	YMILL-170-71	39353	Washer
72	YMILL-170-72	39354	Strut
75	YMILL-170-75	39357	Screw M6*16
78	YMILL-170-78	39360	Key 5*40
79	YMILL-170-79	39361	Spindle
80	YMILL-170-80	39362	Gear
81	YMILL-170-81	39363	Support block
82	YMILL-170-82	39364	Screw M5*20
83	YMILL-170-83	39365	Pin 4*16
84	YMILL-170-84	39366	Worm
85	YMILL-170-85	39367	Sleeve
86	YMILL-170-86	39368	Pin 3*12

Helpline: (023) 8049 4344. Sales Desk: (023) 8049 4333. General Enquiries: (023) 8026 6355.

DRAPER TOOLS LTD, HURSLEY ROAD, CHANDLER'S FORD, EASTLEIGH, HANTS. SO53 1YF. U.K. internet: www.draper.co.uk e-mail: sales@drapertools.com



SPARE PARTS LISTING SHEET FOR

350W 230V Mill/Drill Machine

Stock No.34023

Part No.MILL-170

KEY No.	PART No.	STOCK No.	DESCRIPTION
87	YMILL-170-87	39369	Pin 3*12
88	YMILL-170-88	39370	Union
89	YMILL-170-89	39371	Bracket
90	YMILL-170-90	39372	Screw M5*25
91	YMILL-170-91	39373	Dial
92	YMILL-170-92	39374	Spring
93	YMILL-170-93	39375	Handlewheel
94	YMILL-170-94	39376	Screw M6*8
95	YMILL-170-95	39377	Shaft
96	YMILL-170-96	39378	Cover
97	YMILL-170-97	39379	Screw M4*6
98	YMILL-170-98	39380	Support of dust cover
99	YMILL-170-99	39381	Screw M5*16
100	YMILL-170-100	39382	Dust guard
101	YMILL-170-101	39384	Clamp bolt M6*12
102	YMILL-170-102	39385	Upper and washer
103	YMILL-170-103	39386	Screw M6*16
104	YMILL-170-104	39387	Set screw M6*6
105	YMILL-170-105	39388	Spring 0.8*4.8*10
106	YMILL-170-106	39389	Steel ball
107	YMILL-170-107	39390	Handle seat
108	YMILL-170-108	39391	Double head bolt M8*70
109	YMILL-170-109	39392	Knob
110	YMILL-170-110		Warning label
111	YMILL-170-111	39393	Control box
112	YMILL-170-112		Label on control
113	YMILL-170-113	39394	Shaft 1
114	YMILL-170-114	39395	Key 4*45
115	YMILL-170-115	39396	Internal Ring 12
116	YMILL-170-116	39397	Spacing ring
117	YMILL-170-117	39399	Small shaft
118	YMILL-170-118	39400	Spacing ring
119	YMILL-170-119	39401	Spindle nut
120	YMILL-170-120	39402	Key 5*20
121	YMILL-170-121	39403	Screw M5*12
122	YMILL-170-122	39404	Bearing cover
123	YMILL-170-123	39405	Ball bearing 80206
124	YMILL-170-124		Name label
125	YMILL-170-125		Fine feeding label
126	YMILL-170-126	39406	Protecting cover
127	YMILL-170-127	39407	Motor
127A	YMILL-170-127A	04669	Key
127B	YMILL-170-127B	04670	Motor gear washer

KEY No.	PART No.	STOCK No.	DESCRIPTION
128	YMILL-170-128	39408	Motor gear
129	YMILL-170-129	39409	Internal ring 9
130	YMILL-170-130	39410	Motor seat
131	YMILL-170-131	39411	Flat screw M6*12
132	YMILL-170-132	39412	Screw M5*10
132-1	YMILL-170-132-1	04671	Washer
133	YMILL-170-133	39414	Green lamp
134	YMILL-170-134	39415	Speed control knob
135	YMILL-170-135	39416	Yellow lamp
136	YMILL-170-136	39417	Fuse box
137	YMILL-170-137	39418	Emergency stop switch
138	YMILL-170-138	39419	Gear
139	YMILL-170-139	39420	Ball bearing 80101
140	YMILL-170-140	39421	Transmission gear
141	YMILL-170-141	39422	Bar
142	YMILL-170-142	39423	Plate
143	YMILL-170-143	39424	Set screw M5*5
144	YMILL-170-144	39425	Self-rapping screw ST2.9*8
145	YMILL-170-145		L/H label
146	YMILL-170-146	39426	Motor cover
147	YMILL-170-147	39427	Motor connecting flange
148	YMILL-170-148	39428	Screw M6*10
149	YMILL-170-149		Warning label
150	YMILL-170-150	03643	PC board
151	YMILL-170-151	03645	Lock sleeve
152	YMILL-170-152	03646	Rotor shaft
153	YMILL-170-153	03647	Key 4x6
154	YMILL-170-154	03648	Spring support
155	YMILL-170-155	03649	Torsion spring
156	YMILL-170-156	03650	Cover
167	YMILL-170-157	03651	Nut
158	YMILL-170-158	03653	Prop
159	YMILL-170-159	03654	Supporting shank
160	YMILL-170-160	03655	Screw
161	YMILL-170-161	03656	Washer
162	YMILL-170-162	03657	Internal ring 12
163	YMILL-170-163	03658	Cover
164	YMILL-170-164	03659	Top cover
165	YMILL-170-165	03661	Screw M3x6

Helpline: (023) 8049 4344. Sales Desk: (023) 8049 4333. General Enquiries: (023) 8026 6355.

DRAPER TOOLS LTD, HURSLEY ROAD, CHANDLER'S FORD, EASTLEIGH, HANTS. SO53 1YF. U.K. internet: www.draper.co.uk e-mail: sales@drapertools.com



SPARE PARTS DRAWING SHEET FOR

350W 230V Mill/Drill Machine

Stock No.34023

Part No.MILL-170

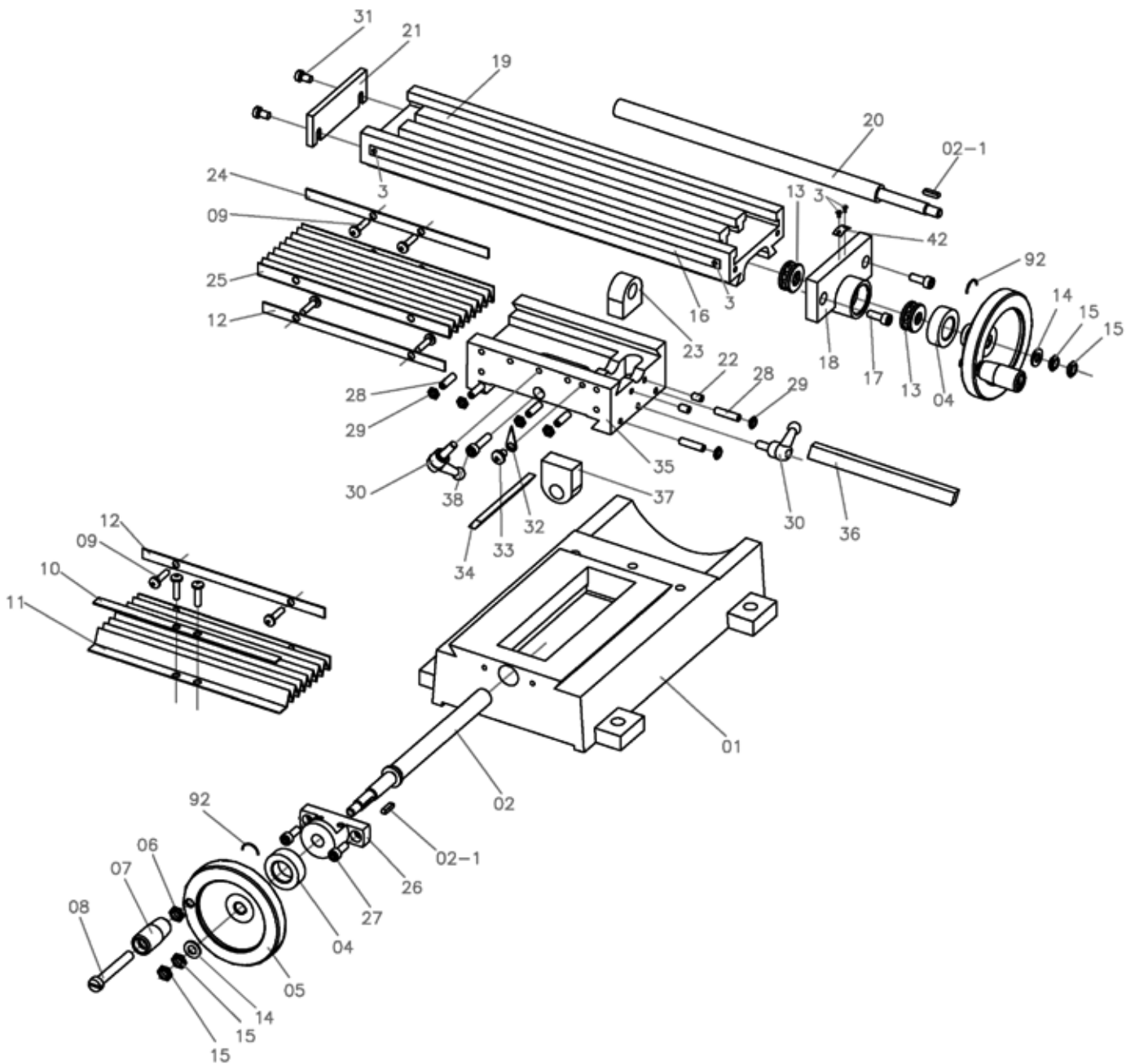

Helpline: (023) 8049 4344. Sales Desk: (023) 8049 4333. General Enquiries: (023) 8026 6355.

DRAPER TOOLS LTD, HURSLEY ROAD, CHANDLER'S FORD, EASTLEIGH, HANTS. SO53 1YF. U.K. internet: www.draper.co.uk e-mail: sales@drapertools.com



SPARE PARTS DRAWING SHEET FOR

350W 230V Mill/Drill Machine

Stock No.34023

Part No.MILL-170

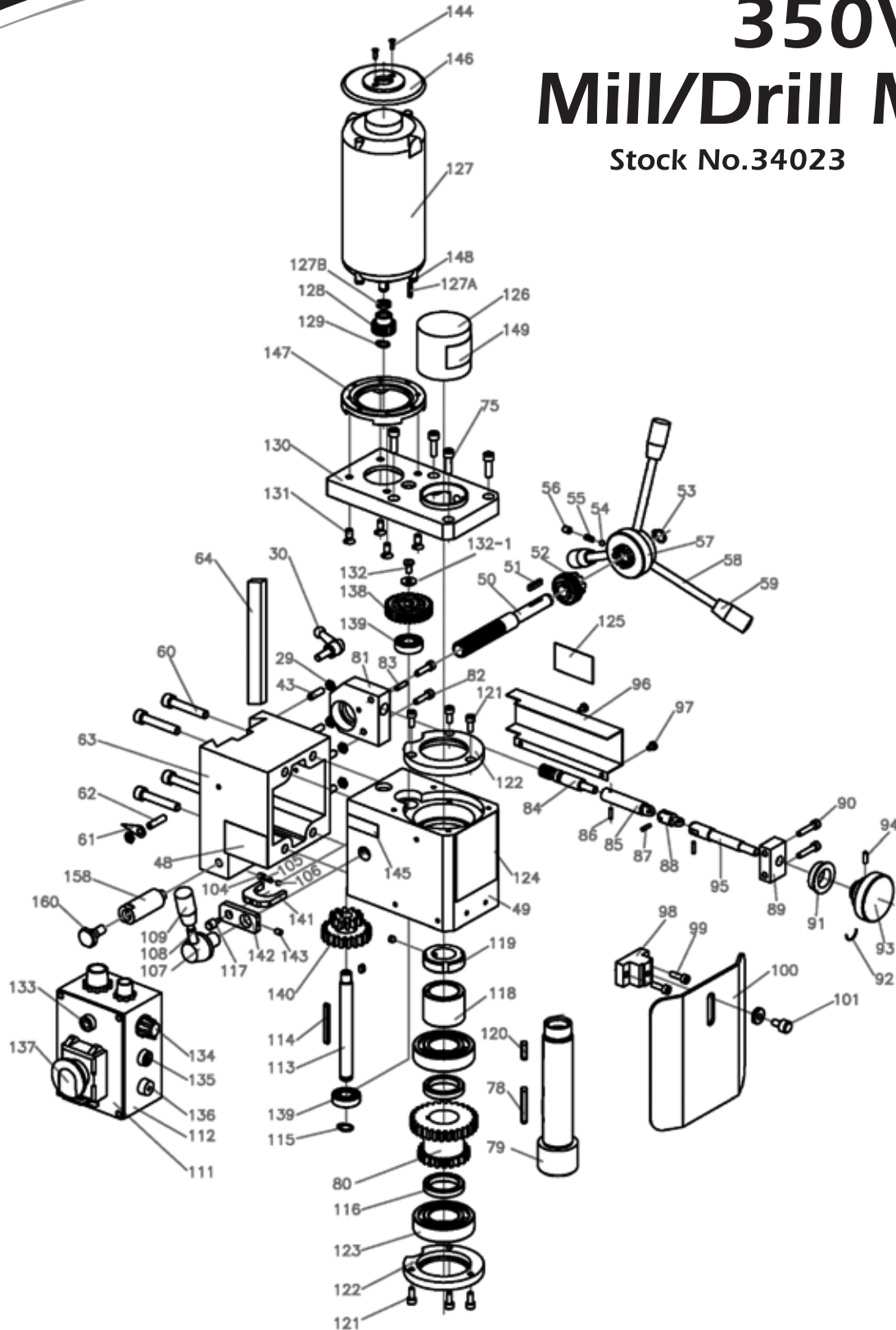

Helpline: (023) 8049 4344. Sales Desk: (023) 8049 4333. General Enquiries: (023) 8026 6355.

DRAPER TOOLS LTD, HURSLEY ROAD, CHANDLER'S FORD, EASTLEIGH, HANTS. SO53 1YF. U.K. internet: www.draper.co.uk e-mail: sales@drapertools.com

