



BLACK EDITION 10 DRAWER MOBILE WORKSTATION

MODEL NO: **AP5210BE**

Thank you for purchasing a Sealey product. Manufactured to a high standard, this product will, if used according to these instructions, and properly maintained, give you years of trouble free performance.

IMPORTANT: PLEASE READ THESE INSTRUCTIONS CAREFULLY. NOTE THE SAFE OPERATIONAL REQUIREMENTS, WARNINGS & CAUTIONS. USE THE PRODUCT CORRECTLY AND WITH CARE FOR THE PURPOSE FOR WHICH IT IS INTENDED. FAILURE TO DO SO MAY CAUSE DAMAGE AND/OR PERSONAL INJURY AND WILL INVALIDATE THE WARRANTY. KEEP THESE INSTRUCTIONS SAFE FOR FUTURE USE.



Refer to instructions



Wear protective gloves

1. SAFETY

- ❑ **WARNING!** Ensure Health & Safety, local authority, and general workshop practice regulations are adhered to when using this product.
- ❑ **WARNING!** Use storage on level and solid ground, preferably concrete.
- ❑ **WARNING!** Fill from the bottom drawer up. If the tool cabinet is filled from the top drawer down, it will be top heavy and may fall over.
- ✓ Locate in a suitable, well lit, clean and hazard free work area.
- ✓ When moving the cabinet **DO NOT** pull it. Push the cabinet to prevent injury.
- ✓ Close and lock the drawers before moving the cabinet. If the drawers came open they could make the cabinet unstable.
- ✓ Apply the brakes when in desired position.
- ✓ Be aware of sharp edges, wear gloves.
- ✓ Keep the work area clean, uncluttered and ensure there is adequate lighting.
- ✓ Keep the storage system clean and tidy in accordance with good workshop practice.
- ✓ Keep children and unauthorised persons away from the work area.
- * **DO NOT** open more than one drawer at a time.
- * **DO NOT** attempt to lift by the side handles, use chains, ropes or other lifting devices.
- * **DO NOT** step or climb on the product or on the drawers.
- * **DO NOT** use the storage system for any purpose other than that for which it is designed.
- * **DO NOT** place the storage system in a damp or wet location or an area where there is condensation.
- * **DO NOT** clean the storage system with any solvents which may damage the surfaces or the protective coating.
- * **DO NOT** move the storage system when there are items placed inside.
- * **DO NOT** overload the storage system.
- * **DO NOT** mount on a truck bed or any other moving object.
- * **DO NOT** alter the product in any way, e.g. do not weld on external lock bars or attach electrical equipment. Alterations may cause damage to the product or cause personal injury.

2. INTRODUCTION

Heavy-duty steel construction and manufactured with steel inner walls for extra strength and durability. Fitted with four Ø125mm PP wheels with black chrome effect alloys, two fixed and two swivel with brakes. Rust and solvent resistant black crinkle effect finish with anodized black drawer and cupboard handles. Supplied with 25mm thick rubber wood worktop. 10 soft close drawers on 45mm ball bearing slides, 2 cupboard and pegboard back panel. Drawers and cupboard fitted with cylinder locks and each supplied with 2 keys. Some simple assembly required.

3. SPECIFICATION

| | |
|---------------------------------|---------------------|
| Model No: | AP5210BE |
| Overall Size (W x D x H): | 1421 x 650 x 1860mm |
| Large Full length Drawer:..... | 1307 x 552 x 120mm |
| Medium Drawer (x3):..... | 922 x 552 x 79mm |
| X-Large Drawer:..... | 922 x 552 x 230mm |
| Small 1/2 Drawer (x2): | 322 x 552 x 51mm |
| Medium 1/2 Drawer:..... | 322 x 552 x 79mm |
| XL-Large 1/2 Drawer:..... | 322 x 552 x 230mm |



4. CONTENTS

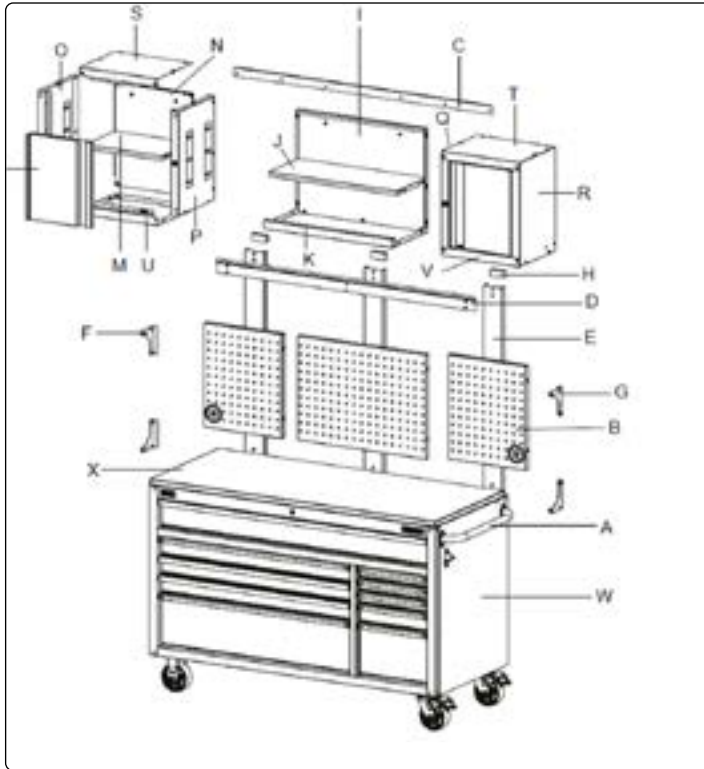

| Part | Description | No. |
|------|---------------------------------------|-----|
| A | Cabinet handle | 1 |
| B | Pegboard | 3 |
| C | Mounting bracket | 1 |
| D | Connecting brace | 1 |
| E | Backwall | 3 |
| F | L-shaped bracket (left) | 2 |
| G | L-shaped bracket (right) | 2 |
| H | EVA sticker | 3 |
| I | Back panel | 1 |
| J | Shelf | 1 |
| K | Bottom panel | 1 |
| L | Door | 2 |
| M | Shelf (wall cabinet) | 2 |
| N | Back panel (wall cabinet) | 2 |
| O | Left side panel (left wall cabinet) | 1 |
| P | Right side panel (left wall cabinet) | 1 |
| Q | Left side panel (right wall cabinet) | 1 |
| R | Right side panel (right wall cabinet) | 1 |
| S | Top panel (left wall cabinet) | 1 |
| T | Top panel (right wall cabinet) | 1 |
| U | Bottom panel (left wall cabinet) | 1 |
| V | Bottom panel (right wall cabinet) | 1 |
| W | Cabinet | 1 |
| X | Rubber wood top | 1 |

5. ASSEMBLY

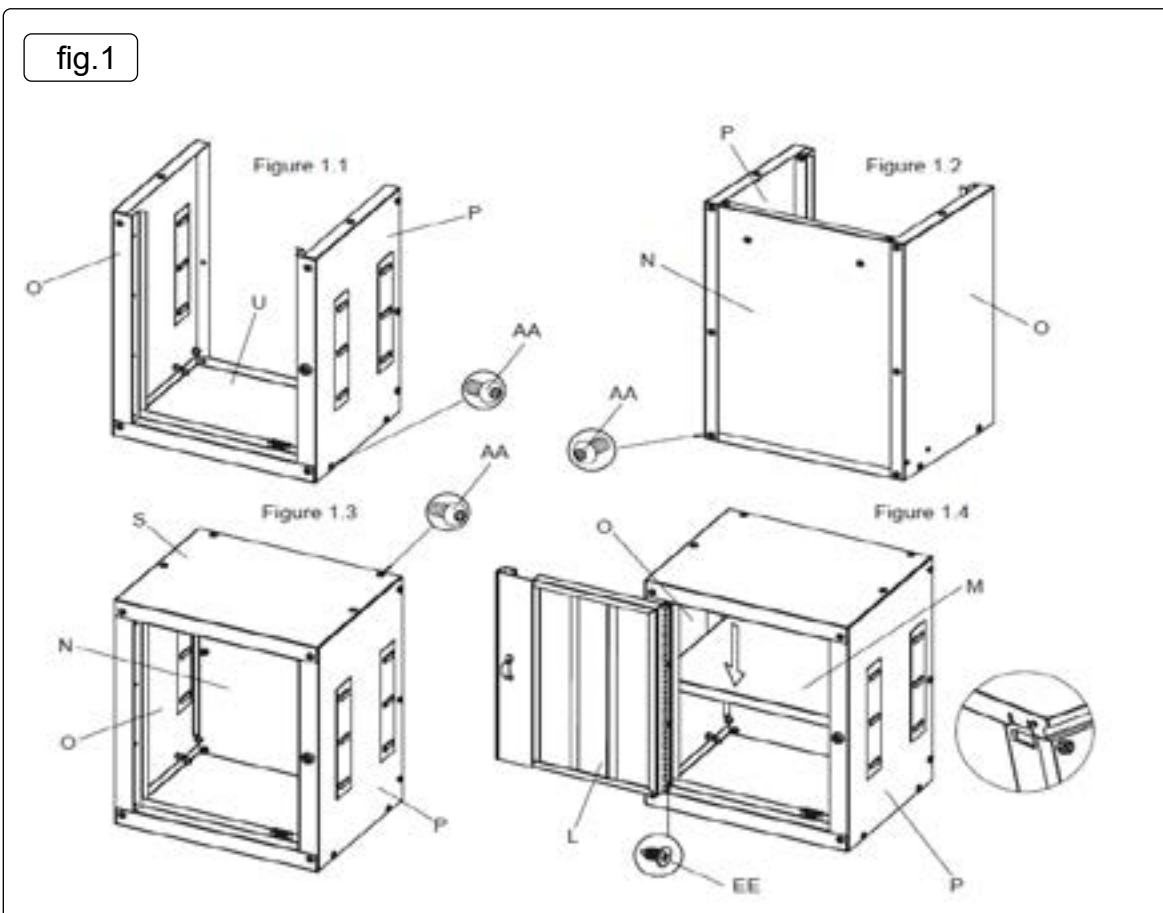

- ❑ **WARNING!** It is recommended that two people are involved in this assembly.
- ✓ **NOTE:** The holes in the top cabinet are already tapped and do not require nuts.
- ✓ **NOTE:** Side panels and back panel tabs (flanges) must be positioned on inside of cabinet facing up.

5.1. WALL CABINET ASSEMBLY (fig.1)

- 5.1.1. For left side wall cabinet, attach side panels (O & P) to bottom panel (U) with M6 x 16mm bolts (AA) and tighten with supplied hex key. Do not fully tighten. See Figure 1.1
- 5.1.2. Insert back panel (N) inside the two side panels (O & P) and bottom (U). Align and insert M6 x 16mm bolts (AA) into holes and tighten with supplied hex key. See Figure 1.2
- 5.1.3. Place top panel (S) over sides (O & P) and back (N). Align holes on top (S), sides (O & P) and back (N) then tighten with M6 x 16mm bolts (AA) and supplied hex key. Do not fully tighten. See Figure 1.3
- 5.1.4. Square up cabinet on a level surface and fully tighten all M6 x 16mm bolts (AA) with supplied hex key.
- 5.1.5. Align the holes on the hinge of the door (L) to the holes on left side panel (O) then tighten with flat head tapping screws (EE) and screwdriver (not included). Ensure the door is squared and flush with the cabinet before tightening the screws. See Figure 1.4
- 5.1.6. With the door (L) open insert the shelf panel (M) into cabinet. Determine the desired height of shelf (M) and secure by inserting shelf edges into the tab flanges on the two side panels (O & P). If flanges appear tight, lightly pry to loosen. The left side wall cabinet assembly is complete.
- 5.1.7. Repeat this process for the right side wall cabinet using side panels (Q & R).

5.2. WALL CABINET SHELF ASSEMBLY (fig.2)

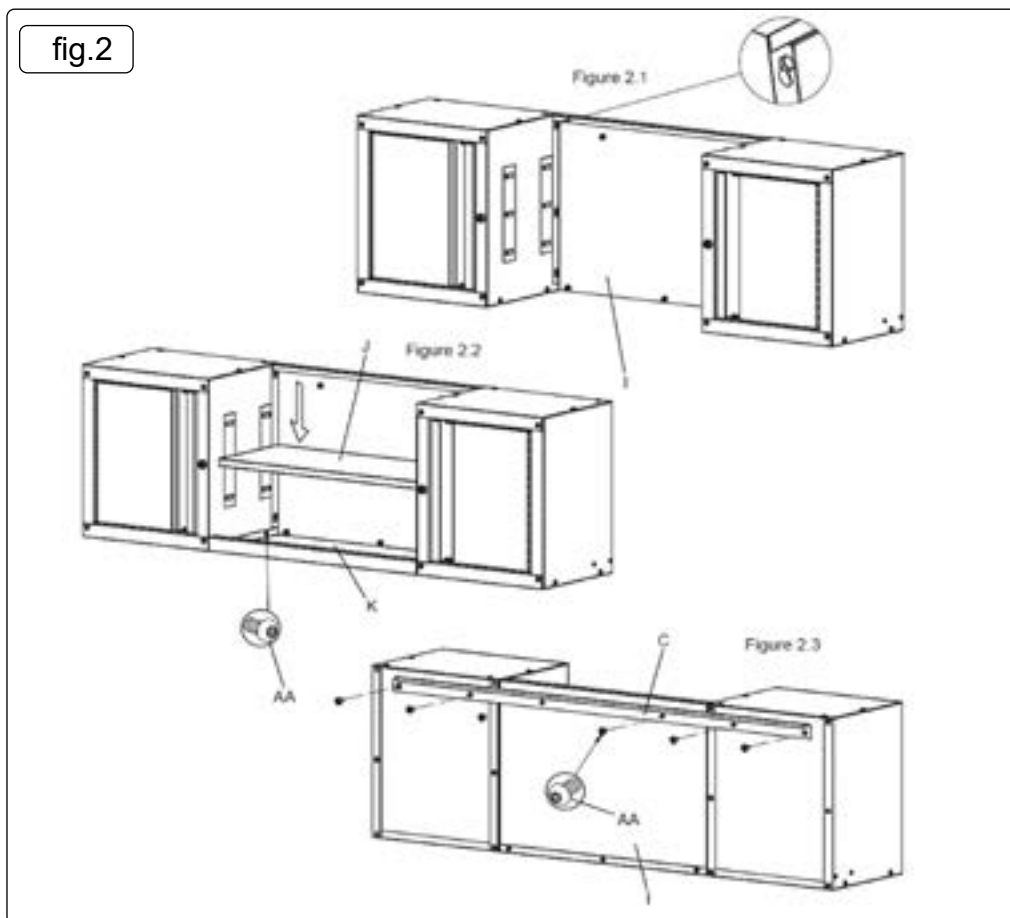

- 5.2.1. Insert back panel (I) between the two wall cabinets and secure the pins in the key holes. Ensure the top of the back panel (I) is flush with the top of the cabinets. See Figure 2.1
- 5.2.2. Attach both wall cabinets to bottom panel (K) with M6 x 16mm bolts (AA) and tighten with supplied hex key. See Figure 2.2
- 5.2.3. Determine the desired height of shelf (J) and secure by inserting shelf edges into the tab flanges on the right (or left) panel of wall cabinets. If flanges appear tight, lightly pry to loosen.
- 5.2.4. Align mounting bracket (C) holes to the back panel (I) and wall cabinets, tighten with M6 x 16mm bolts (AA) and supplied hex key. See Figure 2.3.

5.3. ATTACH CABINET HANDLE (fig.3)

NOTE: There are holes to mount handle on either side of cabinet, but only one handle comes with this cabinet.

- 5.3.1. Position the cabinet handle (A) over the holes on the cabinet (W).
- 5.3.2. Attach with M6 x 16mm bolts (AA) and tighten with supplied hex key.

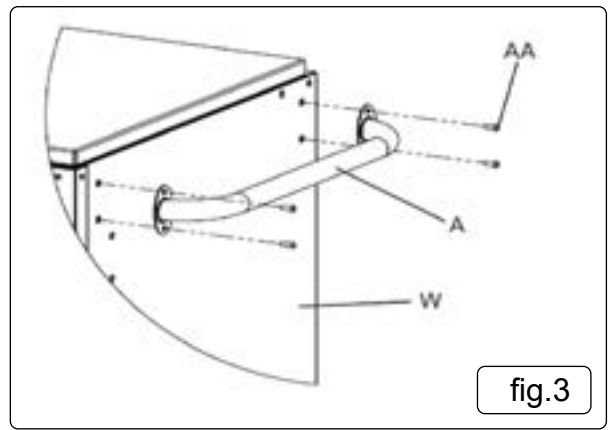

5.4. ATTACH PEGBOARD (fig.4)

- 5.4.1. Position the backwalls (E) over the holes on the cabinet (W).
- 5.4.2. Secure with (4) M8 x 20mm bolts (BB), spring washers (CC) and flat washers (DD) per backwall (E) and tighten with supplied hex key or 12mm wrench/socket (not included).

× **DO NOT** fully tighten bolts at this time. See Figure 4.1

- 5.4.3. Align the connecting brace (D) holes to upper holes of mounting bracket (C), tighten with (6) M6 x 16mm bolts (AA) and supplied hex key. Do Not fully tighten bolts at this time. See Figure 4.2
- 5.4.4. Position each piece of pegboard (B) over the holes on backwalls (E). Please note the grommet position in the left and right pegboard panels in Figure 4.2
- 5.4.5. Secure the pegboard panels (B) with (10) M6 x 16mm bolts (AA) and tighten with supplied hex key.
- 5.4.6. Once the pegboard panels (B) are secured and squared, go back and tighten all hardware in this step.

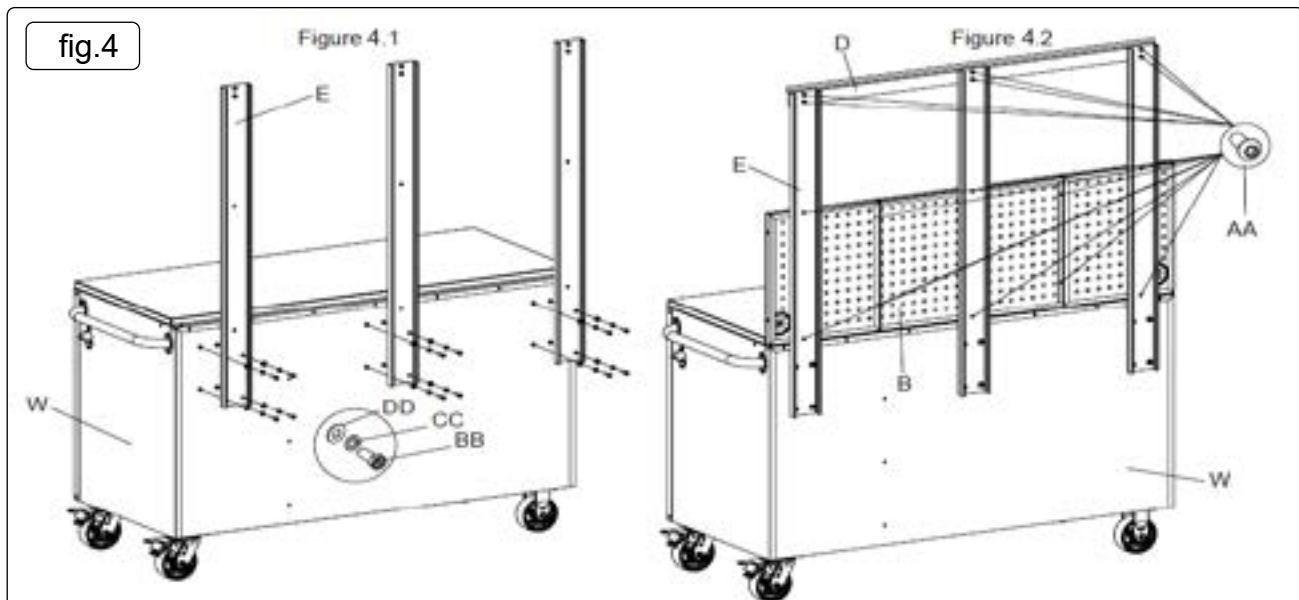

5.5. ATTACH WALL CABINET SYSTEM TO THE CABINET (fig.5)

- 5.5.1. Peel off the paper back from the EVA stickers (H), then attach in appropriate position toward bottom of wall cabinet's back. See Figure 5.1
- 5.5.2. Hang wall cabinets onto connecting brace (D) and ensure the cabinet mounting bracket (C) is properly seated on the connecting brace (D). See Figure 5.2
- 5.5.3. Secure the wall cabinets to the backwalls by positioning the L-shaped brackets (F&G) over the holes on the pegboard (B) and the wall cabinet. See Figure 5.3
- 5.5.4. Attach with (3) M6 x 16mm bolts (AA) per L-shaped brackets (F&G) and tighten with supplied hex key.
- 5.5.5. Repeat this process for the other side of the pegboard (B) to attach the wall cabinet to the cabinet (W).

NOTE: Wall cabinet may need to be hung on connecting brace to determine the appropriate position for EVA sticker.

Figure 5.1

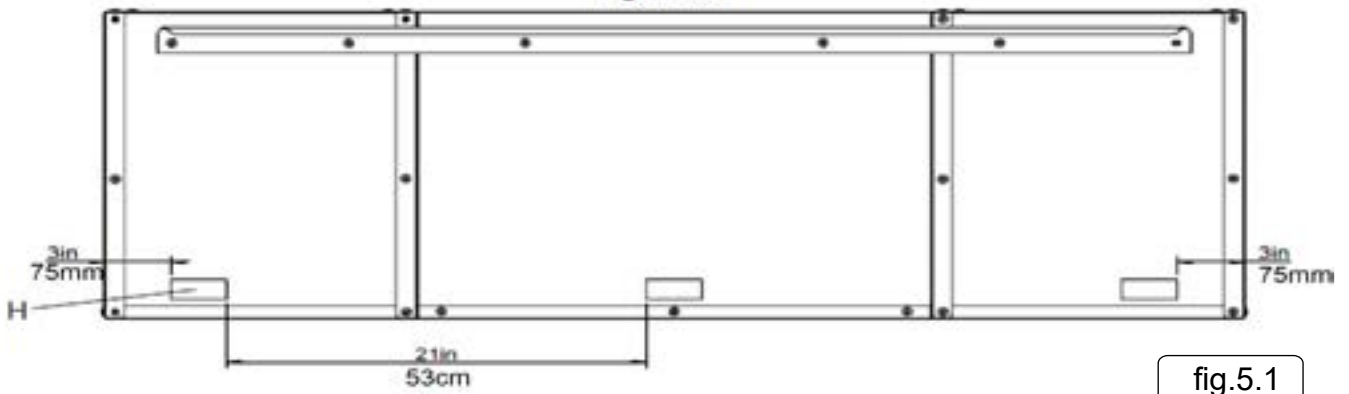

fig.5.1

Figure 5.2

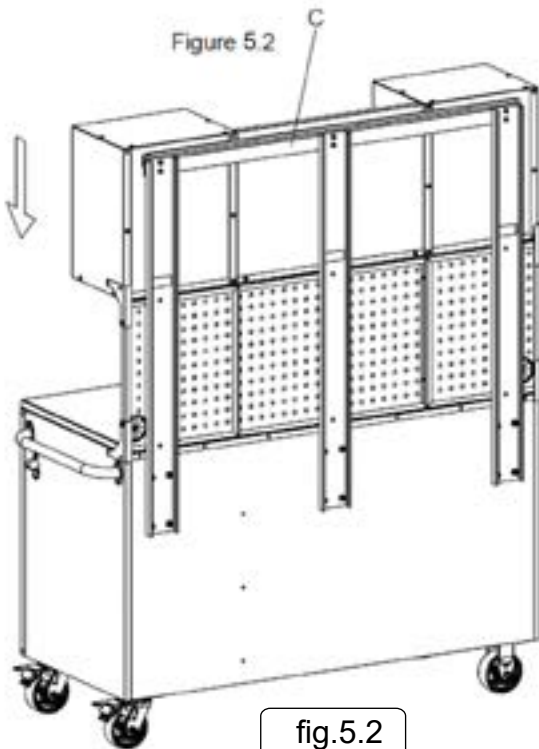

fig.5.2

Figure 5.3

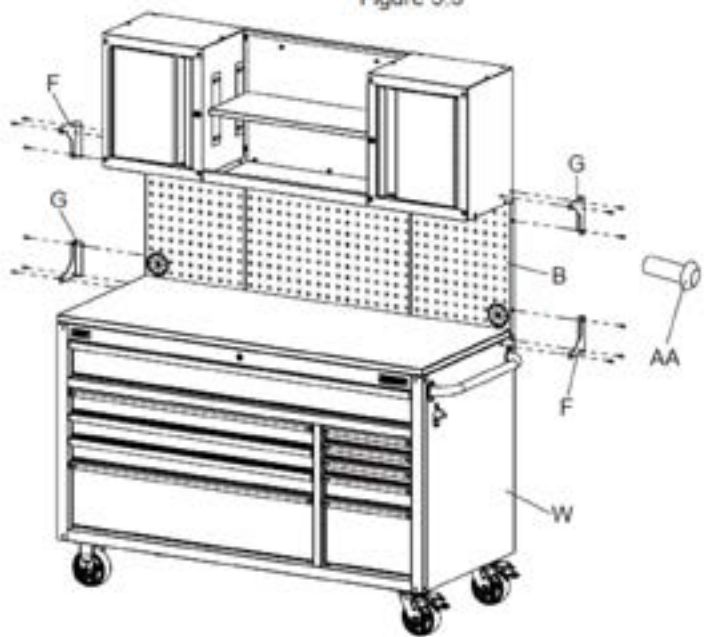

fig.5.3

5.6. REMOVING AND REPLACING DRAWERS (fig.6)

- 5.6.1. Pull the drawer completely out.
- 5.6.2. Press down the right tab and lift up the left tab.
- 5.6.3. Pull drawer off slides.
- 5.6.4. To reinstall the drawer, realign with the internal drawer slide and push in until locked in place.

6. MAINTENANCE

- 6.1. Periodically lubricate wheel axles and tighten all nuts and bolts.
- 6.2. Lubricate the drawer slides sparingly every six months.
- 6.3. Keep all surfaces clean. Brush off and wipe down with a damp cloth and mild detergent to maintain finish.
- 6.4. Stubborn grease and oil marks can be removed by using a non-abrasive cleaner.

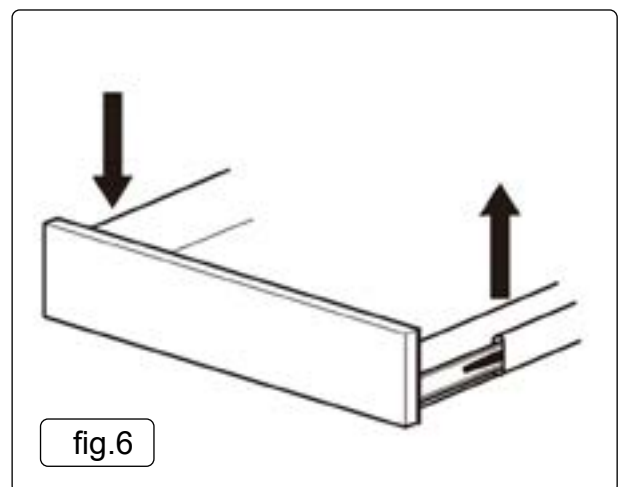

fig.6



ENVIRONMENT PROTECTION

Recycle unwanted materials instead of disposing of them as waste. All tools, accessories and packaging should be sorted, taken to a recycling centre and disposed of in a manner which is compatible with the environment. When the product becomes completely unserviceable and requires disposal, drain any fluids (if applicable) into approved containers and dispose of the product and fluids according to local regulations.

Note: It is our policy to continually improve products and as such we reserve the right to alter data, specifications and component parts without prior notice.

Important: No Liability is accepted for incorrect use of this product.

Warranty: Guarantee is 12 months from purchase date, proof of which is required for any claim.



REGISTER YOUR
PURCHASE HERE

Sealey Group, Kempson Way, Suffolk Business Park, Bury St Edmunds, Suffolk. IP32 7AR



01284 757500



sales@sealey.co.uk



www.sealey.co.uk