



# WELDING HELMET WITH AIR PURIFYING RESPIRATOR AUTO DARKENING SHADE 5-8 & 9-13

MODEL NO: **PWH615**

Thank you for purchasing a Sealey product. Manufactured to a high standard, this product will, if used according to these instructions, and properly maintained, give you years of trouble free performance.

**IMPORTANT:** PLEASE READ THESE INSTRUCTIONS CAREFULLY. NOTE THE SAFE OPERATIONAL REQUIREMENTS, WARNINGS & CAUTIONS. USE THE PRODUCT CORRECTLY AND WITH CARE FOR THE PURPOSE FOR WHICH IT IS INTENDED. FAILURE TO DO SO MAY CAUSE DAMAGE AND/OR PERSONAL INJURY AND WILL INVALIDATE THE WARRANTY. KEEP THESE INSTRUCTIONS SAFE FOR FUTURE USE.



Refer to  
instructions

## 1. SAFETY

- ❑ **WARNING!** This helmet is not suitable for use with laser welding or CUTTING or for overhead welding applications.
- ✓ Ensure all workshop safety rules, regulations and conditions are complied with when using welding equipment. The helmet will not offer protection against misuse of workshop tools, equipment, or accessories.
- ✓ Maintain the helmet in good condition and protect cartridge from liquid and dirt contact. Regularly replace the protective lens and replace any damaged or worn parts. Use genuine parts only. Unauthorised parts may be dangerous and will invalidate the warranty.
- ✓ Ensure the front cover window is securely in place before use.
- ✓ Fit the helmet and adjust the head band so the helmet will sit as low and near to your face as possible.
- ✓ Use helmet only in temperatures ranging from -5°C to 55°C.
- ✓ Remove ill fitting clothing, remove ties, watches, rings and other loose jewellery.
- ✓ Maintain correct balance and footing.
- ✓ Ensure the floor is clear from obstructions, not slippery and wear non-slip protective shoes.
- ✓ Keep children and unauthorised persons away from the working area.
- ❑ **WARNING!** The helmet will only protect the eyes and face from radiation and sparks. It will not protect against explosive devices or corrosive liquids.
- \* **DO NOT** use helmet for any purpose for which it is not designed.
- \* **DO NOT** use helmet unless you have been instructed in its use by a qualified person.
- \* **DO NOT** open or tamper with the shade cartridge.
- \* **DO NOT** get the helmet wet or use in damp or wet locations.
- \* **DO NOT** leave work place with helmet in lowered position, as bright light source may darken cartridge unexpectedly.
- \* **DO NOT** place the helmet on a hot surface.
- \* **DO NOT** use helmet without front cover window fitted. To do so will invalidate your warranty.
- ✓ Clean helmet (see section 5.5) and store the helmet in a safe, dry, childproof location.
- ❑ **WARNING!** Before welding always inspect the cartridge filter to ensure that it is not damaged. To test the filter prior to welding, direct the front of the cartridge filter to a bright light source which will cause the lens to darken. Then using your hand rapidly cover and uncover the sensor. The filter should lighten momentarily then return to a dark state.
- ❑ **WARNING! DO NOT** use the helmet if damaged or you suspect it may be faulty. (Contact Sealey Stockist).
- ▲ **DANGER! DO NOT** use if, at any time, the face plate in the cartridge FAILS to darken when exposed to a welding spark. Remove cartridge and return to your Sealey stockist for checking.
- ✓ Continued use of the product knowing that the auto darkening feature is NOT FUNCTIONING may DAMAGE YOUR EYES and CAUSE BLINDNESS.
- ▲ **DANGER! DO NOT** wear this respirator system to enter areas where:
  1. Atmospheres are oxygen deficient.
  2. Contaminant concentrations are unknown.
  3. Contaminant concentrations are Immediately Dangerous to Life or Health.
  4. Contaminant concentrations exceed the maximum use concentration determined using the assigned Protection Factor for the specific respirator system.
- ❑ **WARNING!** The Particle filter can not be cleaned. **DO NOT** attempt to remove contamination using for example compressed air as this will destroy the filters, the equipment will not give the expected protection and the warranty will be invalidated.
- ✓ If ventilation is poor, wear an approved air-supplied respirator.
- ✓ Read and understand the Material Safety Data Sheets and the manufacturer's instructions for metals, consumables, coatings, cleaners, and degreasers.
- ✓ Work in confined space only if it is well ventilated, or while wearing an air-supplied respirator. Always have a trained watch-person nearby. Welding fumes and gases can displace air and lower the oxygen level causing injury or death. Be sure the breathing air is safe.
- \* **DO NOT** weld in locations near degreasing, cleaning, or spraying operations. The heat and rays of the arc can react with vapours to form highly toxic and irritating gases.
- \* **DO NOT** weld on coated metals, such as galvanized, lead, or cadmium plated steel, unless the coating is removed from the weld area, the area is well ventilated, and while wearing an air-supplied respirator. The coatings and any metals containing these elements can give off toxic fumes if welded. RESPIRATOR (PAPR) MISUSE can be hazardous. Welding produces fumes and gases. Breathing these fumes and gases can be hazardous to your health.
- ✓ Read and follow these instructions and the safety labels carefully. The powered air purifying respirator (PAPR) helps protect the

user from specific airborne contaminants but must be used correctly to be fully effective. Have an industrial hygienist test the air in your facility to ensure the PAPR provides adequate protection from contaminants in your environment. If you have questions about the respirator, see equipment warning label and consult your Safety Director and a certified Industrial Hygienist.

- ✓ Follow all applicable EN/ANSI/CSA/AS&NZS, and other regulatory guidelines pertaining to the use of respirators.
- ✗ **DO NOT** use the powered air purifying respirator where there is danger of fire or explosion.
- ✗ **DO NOT** use the powered air purifying respirator in windy conditions or negative pressure inside the hood may draw in contaminants from the outside air.
- ✗ **DO NOT** use the powered air purifying respirator without a properly installed spark guard cover. Without the spark guard cover, welding sparks may ignite the filter, or damage the filter and allow unfiltered air into the helmet.
- ✓ The powered air purifying respirator does not supply oxygen. Use the respirator only in atmospheres for which it is EN/ANSI/CSA/AS&NZS approved. **DO NOT** use the respirator where oxygen levels are 19.5% or lower, where contaminant levels are unknown or are immediately dangerous to life or health, or where the contaminant levels exceed the respirator specifications.
- ✗ **DO NOT** enter a hazardous area until you are sure the respirator equipment is correctly assembled, working properly, and properly worn.
- ✓ Before each use, inspect the respirator equipment for damage and verify it operates properly, Before using the respirator, test air flow to verify it is providing an adequate volume of air.
- ✗ **DO NOT** use the powered air purifying respirator without all filter components or with the blower turned off, as hazardous levels of oxygen and carbon dioxide may accumulate in helmet.
- ✓ Always wear the powered air purifying respirator when entering a contaminated area. **DO NOT** remove the respirator until outside the contaminated area.
- ✓ Dangerous contaminants may not smell or be visible. Leave the area immediately if you notice the following:
  - Breathing becomes difficult.
  - You experience dizziness, impaired vision, or eye, nose, or mouth irritation.
  - The powered air purifying respirator alarm sounds.
  - The equipment is damaged.
  - Air flow decreases or stops.
  - If you think the equipment is not supplying adequate protection.
- ✗ **DO NOT** remove the equipment until you are in a safe area.
- ✗ **DO NOT** repair, modify, or disassemble the powered air purifying respirator or use with parts or accessories not supplied by the manufacturer. Use only those components that are part of the approved assembly.
- ✓ Replace damaged or clogged filters. **DO NOT** wash or reuse filters. **DO NOT** clean filters by tapping or with compressed air or filter elements may be damaged. Dispose of used filter elements according to local, state, and federal requirements.
- ✓ The powered air purifying respirator must be used with the helmet, hood, and filters recommended by the manufacturer to provide a respirator system. See the label on the blower for information on the required equipment.
- ✗ **DO NOT** use the powered air purifying respirator belt or shoulder straps(if equipped) as a safety harness.

## 2. INTRODUCTION

PAPR (Powered Air-Purifying System) with Auto Darkening Welding Helmet. Highly efficient filter captures hazardous dust, mists and fumes. Lithium battery powered blower unit gives the user a cooling stream of air to their head and face for up to 8 hours. Features a loud audible and visual alarm to alert user of low battery/low air. The welding helmet has adjustable shade control from 9-13. Fully automatic switching from light to dark on striking arc. Additional shades 5-8 for gas welding/cutting. Solar panel power supply. Features sensitivity and delay controls for switching light to dark. Contoured design helmet with adjustable headband for added comfort. Suitable for MIG, TIG and arc welding. Complies with BS EN 379, BS EN 175 and DIN standards.

## 3. SPECIFICATION

Model No:..... PWH615  
 Grinding Function:..... Yes  
 Operating Temperature: ..... -5°C to +55°C  
 Operating Time Light/Dark: .....0.1ms  
 Power:..... Solar Cells/Rechargeable Lithium Battery  
 Shade Active: ..... 5-8 & 9-13 Variable  
 Shade Inactive: ..... 4  
 Viewing Area: ..... 120 x 100mm

## 4. OPERATION

### 4.1. ADJUSTING THE HELMET

- 4.1.1. Adjust the headgear diameter with the twist knob on the back. The knob is locked until pushed in. Once unlocked, twist clockwise to tighten and counter clockwise to loosen.
- 4.1.2. Adjust the height by snapping the pin on the top band into the hole to lock securely in place.
- 4.1.3. To adjust the viewing angle, loosen the knob on both sides of the helmet and change angle locker to the desired tilt position (5 selection and positioned in the middle by default). Once achieving the desire angle, tighten the knobs until snug. The helmet should still swing up, but it should not drift downward when in place for welding.
- 4.1.4. To adjust the distance between the user's face and ADF, loosen the knobs on both sides of the helmet until the headband can move back and forth freely, reposition the headband at one of the 3 slots as desired (The headband is positioned in the middle by default). This should be done one side at a time and both sides should be located at the same position for proper auto-darkening filter operation.

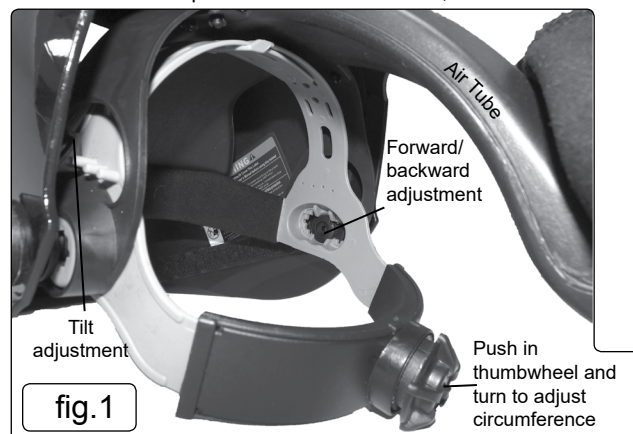

4.2. SHADE GUIDE TABLE

Welding Process	Arc Current(Amperes)																								
	1.5	6	10	15	30	40	60	70	100	125	150	175	200	225	250	300	350	400	450	500	600				
SMW					8				9			10			11				12			13			14
MAG							8	9	10		11			12			13			14					
TIG	8			9			10			11			12		13										
MIG(heavy)								9		10		11			12		13		14						
MIG(light)									10		11		12		13		14								
PAC									9	10	11	12			13										
PAW	4	5	6	7	8	9		10	11		12														
Note	★ SMAW-Covered electrodes ★ MAG-Metal arc Welding ★ TIG-Gas Tungsten Arc Welding ★ MIG(Heavy)-MIG with heavy metals										★ MIG(light)-MIG with light alloys ★ PAC-Plasma jet cutting ★ PAW-Microplasma arc welding														

4.3. SELF-CHECK

4.3.1. Press the TEST Button at any time to see if it automatically switches to dark state and release it to check that the filter returns to the light state. Shade Control; Select the shade DIN 9 to 13 based upon the welding process you will use by consulting the "Shade Guide Table". The variable shade control knob is for internal adjustment. The welding helmet can also be used to protect the face when cutting, from shade DIN 5 to 8. Grind mode DIN 4 prevents filter lens from auto-darkening for grinding use.

4.4. SENSITIVITY CONTROL

4.4.1. The sensitivity can be set from LOW to HIGH by using the sensitivity dial. The LOW setting suits excess ambient light or with another welding machine close by. The HIGH setting suits low amperage welding and welding in areas with low light conditions, especially low amperage argon arc welding. Selections between LOW and HIGH are suitable for most of indoor and outdoor welding operations.

4.5. DELAY CONTROL

4.5.1. When welding ceases, the viewing window automatically changes from dark back to light but with a pre-set delay to compensate. The delay time can be set from MIN (0.1 sec) to MAX (1.0 sec), by Shade Delay Control. The minimum delay suits spot or short welds. The maximum delay suits heavy current welding and reduces eye fatigue from the arc. Selections between MIN and MAX are suitable for most of indoor and outdoor welding operations.

4.6. CLEANING AND STORING

4.6.1. Keep the sensors, solar cell and filter lens clean. Clean filter cartridge and helmet shell by using a soapy water solution and soft cloth.

\* DO NOT use solvents or abrasive cleaning detergent. Switch the product to Grind Mode and put it in a clean, dry location for storage.

4.7. INSTALLING THE BATTERY

- \* DO NOT allow battery to get wet.
  - \* DO NOT attempt to open the battery case.
  - ✓ Keep battery away from fire or heat.
  - ✓ Charge battery before first use.
- 4.7.1. Push the battery into blower body until battery snaps into position. Press the button on the end to assist with this.
- 4.7.2. To release, push the button on the end in and pull out.

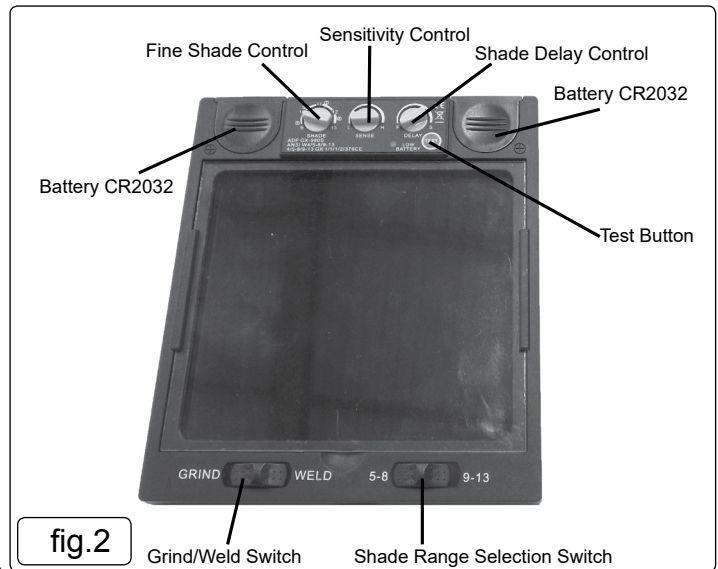

fig.2



fig.3

**4.8. INSTALLING THE AIR FILTER**

✗ **DO NOT** use the respirator without the Foam Prefilter and HEPA Filter installed (fig.4).

✓ Replace damaged or dirty air filter.

4.8.1. Install the HEPA Filter into the cover. Install the Foam Prefilter above the HEPA Filter. Push down the cover until it “clicks” into position as shown.

**NOTE:** Filter Screen and Foam Prefilter protects and increases the life time of the particle filter

**4.9. ATTACHING THE BREATHING TUBE**

4.9.1. Insert tube connector into blower body outlet until snug and then turn connector 1/8 turn to the right to lock it into place (fig.6).

4.9.2. Insert the breathing tube terminal 1 into the headgear terminal and turn the tube clockwise until breathing tube locks in position.

**4.10. TEST AIR FLOW**

4.10.1. Disconnect breathing tube from hood. Insert flowmeter into breathing tube (fig.7). Hold flowmeter straight up and start blower.

4.10.2. The flowmeter ball should float above minimum mark. If flowmeter reads minimum or below, please check battery and filter elements (fig.5).

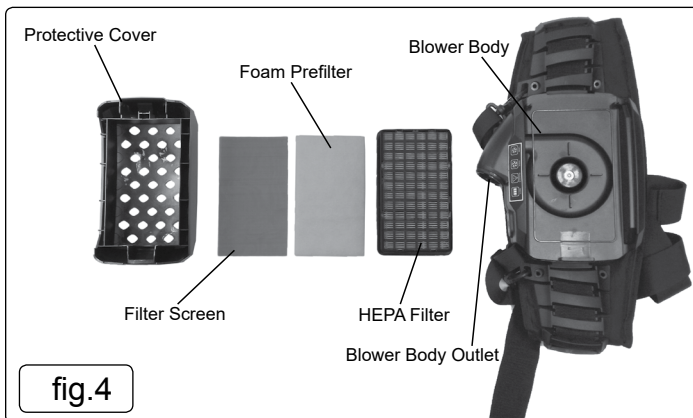

fig.4

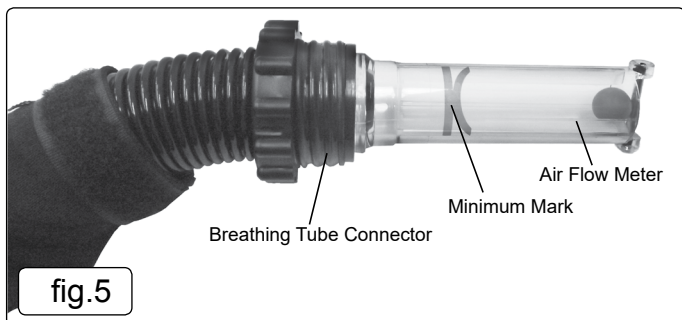

fig.5

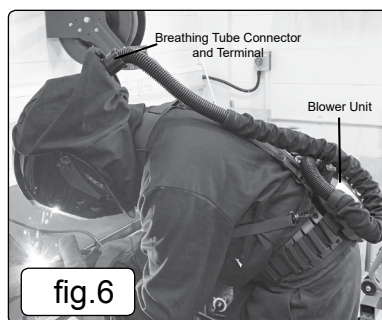

fig.6



fig.7

**4.11. TESTING AIR FLOW ALARM**

4.11.1. Disconnect breathing tube from hood. Start blower and block air flow by placing your hand over the end of breathing tube. Continue blocking air flow until alarm sounds and the blower vibrates. If alarm does not sound and the blower does not vibrate, check battery and filter element.

**4.12. OPERATING THE CONTROLS (FIG.8)**

4.12.1. **TO START:** Press On button for 1 second until the blower starts. The Danger ,Low Speed, High Speed Indicator lights go on, then go out, the alarm sounds, and the blower vibrates momentarily. Then the blower always starts at the low speed. Press the SELECT button to switch between low and high speeds.

4.12.2. **TO STOP:** Press Off button for 1 second until the audible alarm and blower stop. The Danger Indicator light goes on, the alarm sounds, and blower vibrates if battery power is low or air flow is reduced due to a dirty filter,blocked breathing tube, or other problem.

**4.13. BATTERY LEVEL INDICATOR LIGHT**

- Green light goes on: battery level ≥ 90%
- Yellow light goes on: 30% ≤ battery level < 90%
- Red light goes on: 10% < battery level < 30%
- Red light flash: battery level ≤10%

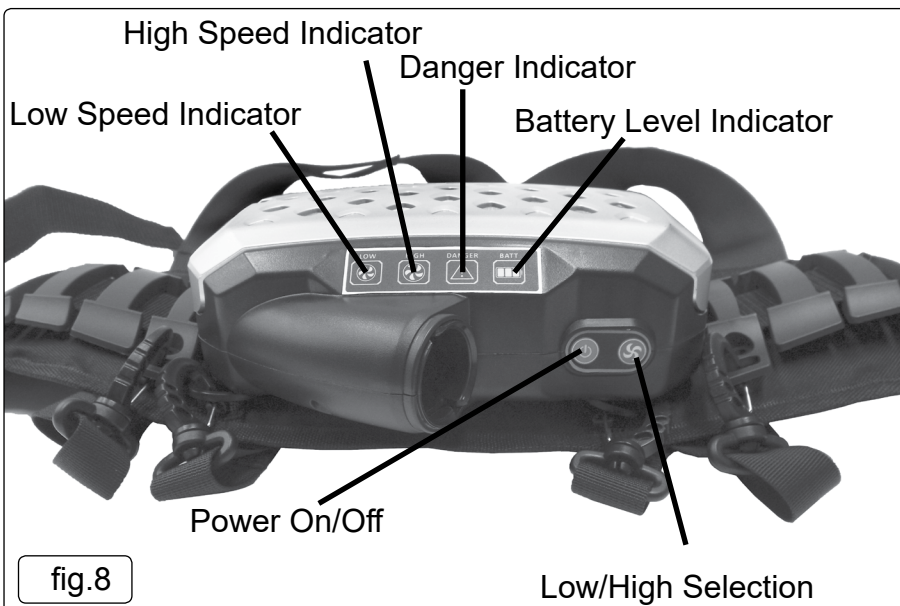

fig.8

#### 4.14. CHECKING THE RESPIRATOR BEFORE USE

Before using the respirator, check the following items:

- ✓ Face seal; Inspect the face seal and replace if damaged.
- ✓ Air Filter Assembly; Verify the air filter is suitable for the application. Also be sure the filter is undamaged, and securely connected to the blower assembly.
- ✓ Breathing Tube; Be sure the tube is undamaged and properly connected to the blower assembly and hood.
- ✓ Battery; Verify the battery is fully charged and securely connected to the blower assembly.
- ✓ Air Flow; Test air flow according to Section 4.10.
- ✓ Air Flow Alarm; Turn on blower assembly and check for audible, visual, and vibratory alarms.
- ✓ Hood; Inspect the hood and replace if damaged.

## 5. MAINTENANCE

### 5.1. FRONT COVER LENS REPLACEMENT

5.1.1. Replace the front cover lens if it is damaged (cracked, scratched, pitted or dirty). Remove the old front cover lens by pressing two lock switches at the bottom of the retaining frame and pull the frame and ADF out. Take the old front cover lens out, and remove any protective film before installing the new one.

### 5.2. INSIDE COVER LENS REPLACEMENT

5.2.1. Replace the inside cover lens if it is damaged (cracked, scratched, pitted or dirty). Place your finger or thumb into the recess and flex the inside cover lens upwards until it releases from one edge. Then remove any protective film before installing the new one.

### 5.3. BATTERIES REPLACEMENT

5.3.1. When Low Voltage Indicator turns red, you have to change the batteries. Replace batteries by removing ADF from the retaining frame. Slide cover plates on the top left and right, and replace the old batteries with lithium batteries. After that, put on cover plates of batteries and install ADF back to frame (fig.9).

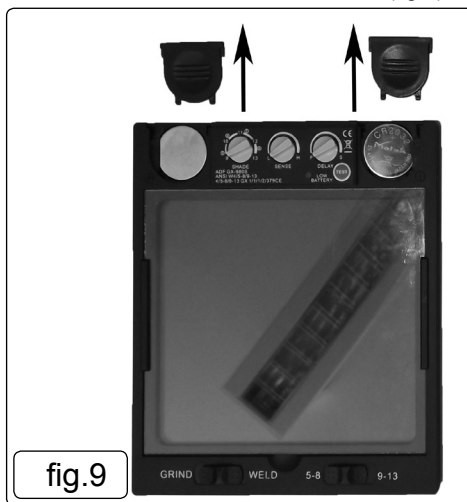

### 5.4. REPLACING THE FILTERS

5.4.1. Push down the cover until it “clicks” into position as shown (fig.10), lift the top cover and remove the filter.

### 5.5. CLEANING:

5.5.1. Detach the battery pack, breathing tube and the blower. Inspect all parts for damage. Replace all damaged parts prior to storage or next use.

A. Blower: Clean the outer surfaces of PAPP assembly and battery pack with a soft cloth dampened in a solution of water and mild, pH neutral detergent. **DO NOT** immerse the blower or battery pack in water. **DO NOT** use solvents or abrasive cleaners. **DO NOT** attempt to clean the interior of the blower with compressed air or vacuum. Ensure the electrical contacts of the blower and battery pack are dry.

B. Breathing tube: Clean the connection sites on the breathing tube with the water and detergent solution. The breathing tube can be immersed in water for cleaning. The inside of the tube must be completely dried prior to use or storage. Air dry, or dry by connecting to the blower unit and use it to force air through the tube until dry.

C. HEPA filter: Open the filter cover and inspect the HEPA filter. Replace if excessively dirty.

### 5.6. STORAGE:

If the blower will not be used for an extended period, remove the filter and battery and store them in a clean, dry, cool place free of solvent-based vapours.

## 6. TROUBLESHOOTING

### 6.1. WELDING SHIELD;

PROBLEM	POSSIBLE CAUSES	SUGGESTED SOLUTIONS
Difficult to see through filter	Cover lens dirty	Clean or replace cover lens
	Filter lens dirty	Clean filter lens
Filter does not darken when arc is struck	Grind Mode Selected	Adjust to 'Weld' mode.
	Sensors or Solar Panel blocked	Make sure sensors or solar panel are exposed to weld arc without blocking
	Set Sensitivity to LOW	Adjust Sensitivity to required level
	Low voltage of lithium batteries	Replace with new lithium batteries if indicator turns red
Filter darkens without arc	Set Sensitivity to HIGH	Adjust Sensitivity to required level
Filter remains dark after welding	Set Delay to MAX	Adjust Delay to required level

### 6.2. FILTER AND HOOD;

FAULT	POSSIBLE SOLUTION
Blower does not supply air to hood	<ol style="list-style-type: none"> <li>1. Press on to start blower</li> <li>2. Recharge battery</li> <li>3. Verify battery is properly connected to blower</li> <li>4. Remove blockage from blower outlet and breathing tube</li> </ol>
Battery pack's charge lasts less than expected	<ol style="list-style-type: none"> <li>1. Ensure battery pack is fully charged</li> <li>2. Replace battery</li> <li>3. Replace charger</li> <li>4. Check the air filter(HEPA filter &amp; Foam prefilter) ,and replace it if necessary</li> </ol>
Blower cannot be turned off	Press ON/OFF button for one second
Battery red level light is flashing	Charge or replace the battery
Danger light is on, alarm sounds or blower vibrates	Check the blower air flow as section 4.10



#### ENVIRONMENT PROTECTION

Recycle unwanted materials instead of disposing of them as waste. All tools, accessories and packaging should be sorted, taken to a recycling centre and disposed of in a manner which is compatible with the environment. When the product becomes completely unserviceable and requires disposal, drain any fluids (if applicable) into approved containers and dispose of the product and fluids according to local regulations.



#### WEEE REGULATIONS

Dispose of this product at the end of its working life in compliance with the EU Directive on Waste Electrical and Electronic Equipment (WEEE). When the product is no longer required, it must be disposed of in an environmentally protective way. Contact your local solid waste authority for recycling information.



Li-ion

#### BATTERY REMOVAL

Under the Waste Batteries and Accumulators Regulations 2009, Jack Sealey Ltd are required to inform potential purchasers of products containing batteries (as defined within these regulations), that they are registered with Valpak's registered compliance scheme. Jack Sealey Ltd's Batteries Producer Registration Number (BPRN) is BPRN00705.

**Note:** It is our policy to continually improve products and as such we reserve the right to alter data, specifications and component parts without prior notice.

**Important:** No Liability is accepted for incorrect use of this product.

**Warranty:** Guarantee is 12 months from purchase date, proof of which is required for any claim.

Sealey Group, Kempson Way, Suffolk Business Park, Bury St Edmunds, Suffolk. IP32 7AR



01284 757500



01284 703534



sales@sealey.co.uk



www.sealey.co.uk



Parts Information:  
**Welding Helmet with Air Purifying  
 Respirator Auto Darkening Shade 5-8 &  
 9-13**  
**Model No: PWH615**

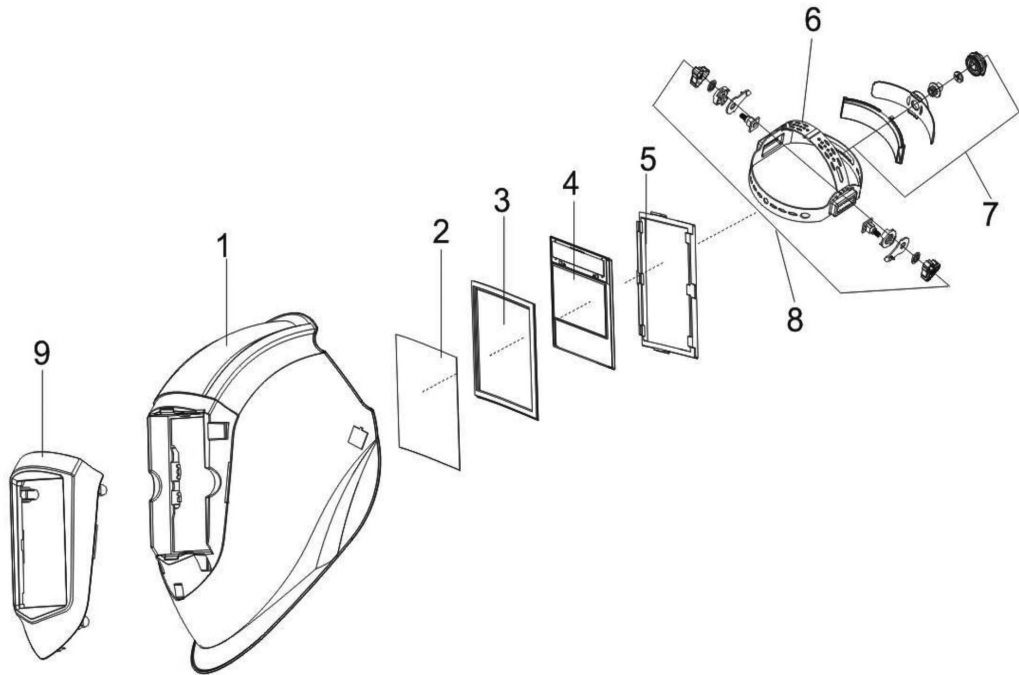

Item	Part No.	Description
1	PWH615.H01	Helmet
2	PWH615.H02	Front Cover Lens
3	PWH615.H03	Rubber Gasket Seal
4	PWH615.H04	Auto-Darkening Cartridge
5	PWH615.H05	Welding Cartridge Frame

Item	Part No.	Description
6	PWH615.H06	Headgear Height Adjusting Pin
7	PWH615.H07	Headgear Diameter Adjusting Knob
8	PWH615.H08	Headgear Angle & Distance Adjusting Knob
9	PWH615.H09	Protective Plate

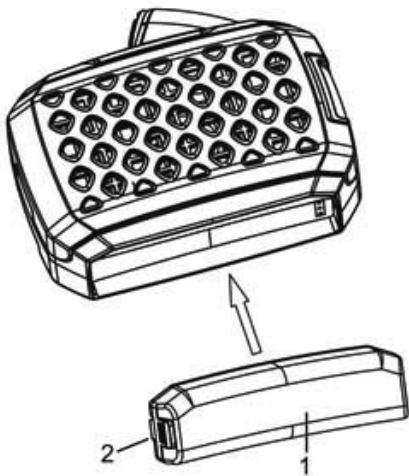

Item	Part No.	Description
1	PWH615.01	Battery
2	PWH615.01A	Lock for Battery

**NOTE:** It is our policy to continually improve products and as such we reserve the right to alter data, specifications and component parts without prior notice. There may be alternative versions of this product, please contact us should you require this information.

**IMPORTANT:** No liability is accepted for incorrect use of product. Spare parts must be fitted by a competent person

**WARRANTY:** Guarantee is 12 months from purchase date, proof of which will be required for any claim.

**Sealey Group**, Kempson Way, Suffolk Business Park, Bury St Edmunds, Suffolk. IP32 7AR



01284 757500



01284 703534



sales@sealey.co.uk



www.sealey.co.uk

Parts Information:  
**Welding Helmet with Air Purifying  
 Respirator Auto Darkening Shade 5-8 &  
 9-13**  
**Model No: PWH615**

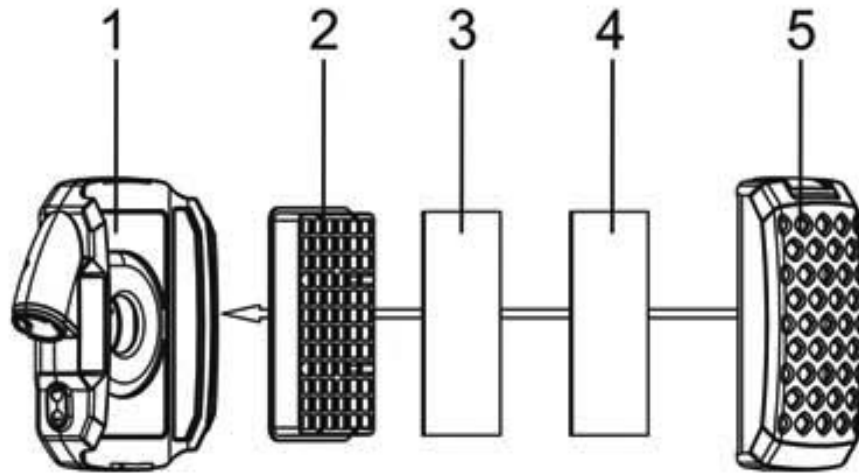

Item	Part No.	Description
1	PWH615.RU01	Filter Body
2	PWH615.02	Filter
3	PWH615.RU03	Form Filter

Item	Part No.	Description
4	PWH615.RU04	Filter Screen
5	PWH615.RU05	Filter Cover

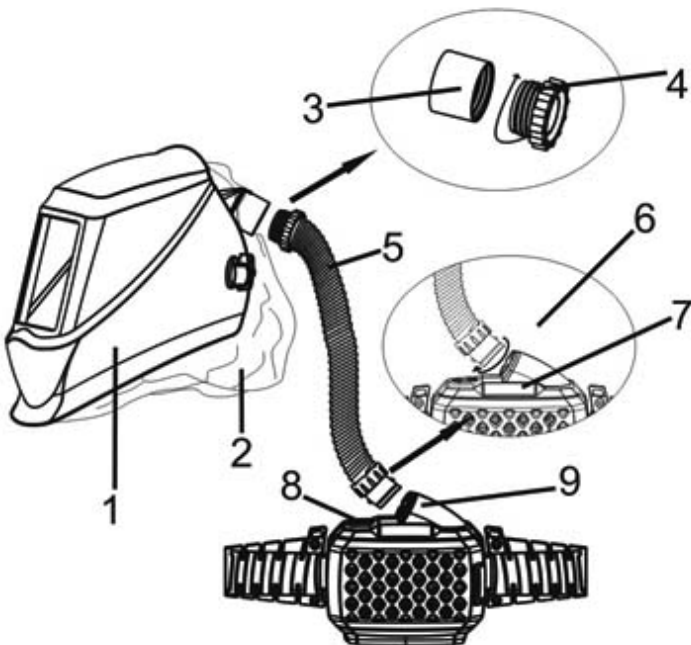

Item	Part No.	Description
1	PWH615.M01	Headshield
2	PWH615.M02	Face Seal
3	PWH615.M03	Headgear Terminal
4	PWH615.M04	Breathing Tube (A)
5	PWH615.M05	Breathing Hose
6	PWH615.M06	Breathing Tube (B)
7	PWH615.M07	Respirator Unit
8	PWH615.M08	Belt
9	PWH615.M09	Respirator Connector

**NOTE:** It is our policy to continually improve products and as such we reserve the right to alter data, specifications and component parts without prior notice. There may be alternative versions of this product, please contact us should you require this information.

**IMPORTANT:** No liability is accepted for incorrect use of product. Spare parts must be fitted by a competent person

**WARRANTY:** Guarantee is 12 months from purchase date, proof of which will be required for any claim.