



7 DRAWER & CUPBOARD 920MM MOBILE WORKSTATION & 10 DRAWER 1140MM MOBILE WORKSTATION

MODEL NO: **AP36MWS & AP45MWS**

Thank you for purchasing a Sealey product. Manufactured to a high standard, this product will, if used according to these instructions, and properly maintained, give you years of trouble free performance.

IMPORTANT: PLEASE READ THESE INSTRUCTIONS CAREFULLY. NOTE THE SAFE OPERATIONAL REQUIREMENTS, WARNINGS & CAUTIONS. USE THE PRODUCT CORRECTLY AND WITH CARE FOR THE PURPOSE FOR WHICH IT IS INTENDED. FAILURE TO DO SO MAY CAUSE DAMAGE AND/OR PERSONAL INJURY AND WILL INVALIDATE THE WARRANTY. KEEP THESE INSTRUCTIONS SAFE FOR FUTURE USE.



Refer to instructions

1. SAFETY

- WARNING!** Ensure Health & Safety, local authority, and general workshop practice regulations are adhered to when using this product.
- DO NOT** open more than one drawer at a time.
- DO NOT** step on the drawers.
- DO NOT** let children play with the roll cab.
- Ensure all drawers are fully closed and the self locking catches are activated, before moving the toolbox.
- Secure the brakes when rollcab is in the desired position.
- Keep the work area clean, uncluttered and ensure there is adequate lighting.
- DO NOT** use in damp work areas.
- WARNING!** The warnings, cautions and instructions referred to in this instruction manual cannot cover all possible conditions and situations that may occur. It must be understood that common sense and caution are factors which cannot be built into this product, but must be applied by the operator.



2. INTRODUCTION

AP36MWS:

Heavy-duty mobile workstation with 7 drawers and cupboard. Drawers run on 45mm ball bearing slides with a weight capacity of 40kg per drawer. All drawer fitted with aluminium handles and 2.5mm EVA non-slip liners. Cupboard and drawers lock separately for safe storage. All panels made of perforated steel for hook storage. Supplied with two shelves to be mounted as required. Top of workstation lined with 10mm EVA mat. Four alloy style 5" castors, two fixed and two swivel with quick release brake. Steel handle at either end for easy mobility.

AP45MWS:

Heavy-duty mobile workstation with 10 drawers. Drawers run on 45mm ball bearing slides with a weight capacity of 40kg per drawer. All drawer fitted with aluminium handles and 2.5mm EVA non-slip liners. Two sets of drawers lock separately for safe storage. All panels made of perforated steel for hook storage. Supplied with two shelves to be mounted as required. Top of workstation lined with 10mm EVA mat. Four alloy style 5" castors, two fixed and two swivel with quick release brake. Steel handle at either end for easy mobility.

3. SPECIFICATION

Model No:	AP36MWS	AP45MWS
(W x D x H):		
Overall Size:.....	1090 x 1025 x 730mm.....	1290 x 1025 x 730mm
Small Drawer:	568 x 398 x 75mm (x5).....	568 x 398 x 75mm (x6)
Medium Drawer:.....	568 x 398 x 154mm (x2).....	568 x 398 x 154mm (x3)
Large Drawer (x1):	N/A.....	568 x 398 x 233mm
Cupboard:	600 x 255 x 470mm.....	N/A

4. ASSEMBLY

- 4.1. Attach the handles (parts 2&3) using the supplied screws (part 4) cover the ends of the screws by using part 5.
- 4.2. Slot the hooks into place using the perforations on the workstation as shown in fig.1.

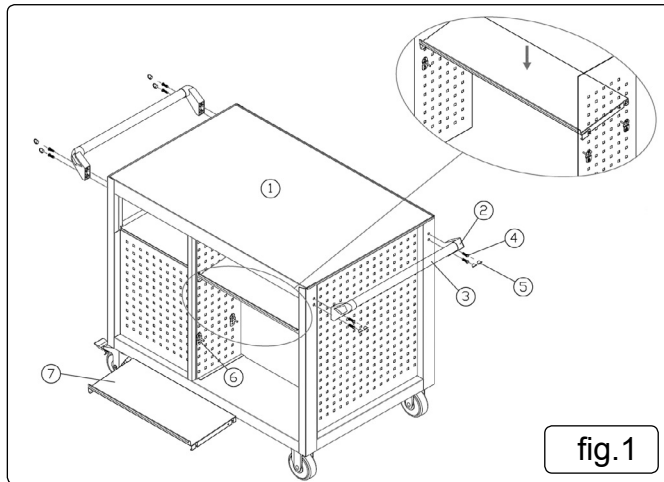

fig.1

	PART NAME	QUANTITY
①		1
②		4
③		2
④		8
⑤		8
⑥		8
⑦		2

5. OPERATION

- ❑ **WARNING!** Only open one drawer at a time and **DO NOT** overload the drawers, fig.2 shows the maximum weight per drawer size.

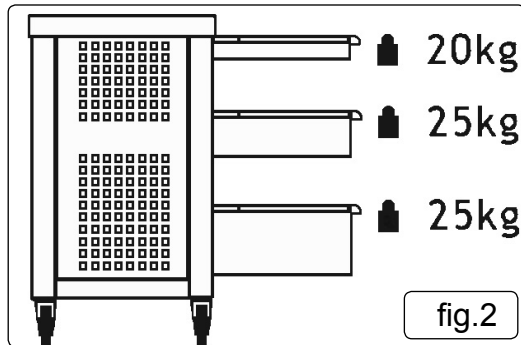

fig.2

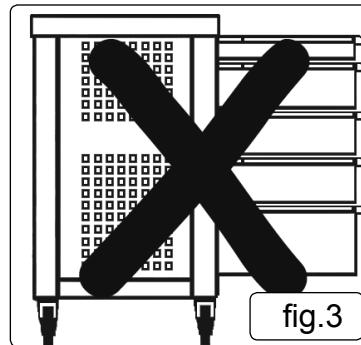

fig.3

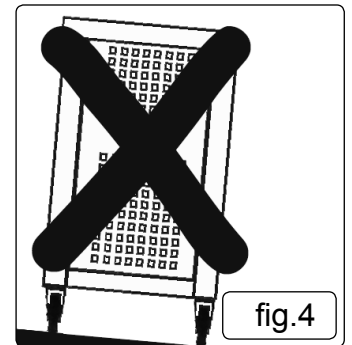

fig.4

- 5.1. When moving the rollcab, ensure that the drawers are closed and locked to prevent accidental opening. Release the brakes as shown in fig.5 and move the rollcab using the handles to maintain full control. When the rollcab has been moved to the required location, lock the brakes (fig.5).

- ❑ **WARNING!** **DO NOT** move across slopes of more than 5° as the rollcab may tilt over (fig.4).

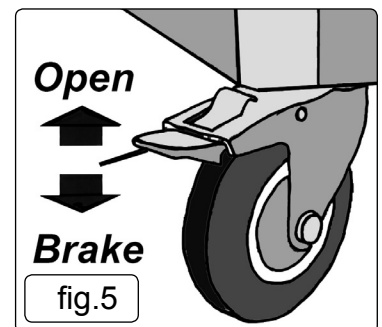

fig.5

Parts support is available for this product. To obtain a parts listing and/or diagram, please log on to www.sealey.co.uk, email sales@sealey.co.uk or telephone 01284 757500



ENVIRONMENT PROTECTION

Recycle unwanted materials instead of disposing of them as waste. All tools, accessories and packaging should be sorted, taken to a recycling centre and disposed of in a manner which is compatible with the environment. When the product becomes completely unserviceable and requires disposal, drain any fluids (if applicable) into approved containers and dispose of the product and fluids according to local regulations.

Note: It is our policy to continually improve products and as such we reserve the right to alter data, specifications and component parts without prior notice.

Important: No Liability is accepted for incorrect use of this product.

Warranty: Guarantee is 12 months from purchase date, proof of which is required for any claim.

Sealey Group, Kempson Way, Suffolk Business Park, Bury St Edmunds, Suffolk. IP32 7AR

01284 757500

01284 703534

sales@sealey.co.uk

www.sealey.co.uk