



INSTRUCTIONS FOR

ELECTRIC HAMMER DRILL Ø13mm 750W/230V

MODEL NO: **SD750**

Thank you for purchasing a Sealey product. Manufactured to a high standard, this product will, if used according to these instructions, and properly maintained, give you years of trouble free performance.

IMPORTANT: PLEASE READ THESE INSTRUCTIONS CAREFULLY. NOTE THE SAFE OPERATIONAL REQUIREMENTS, WARNINGS & CAUTIONS. USE THE PRODUCT CORRECTLY AND WITH CARE FOR THE PURPOSE FOR WHICH IT IS INTENDED. FAILURE TO DO SO MAY CAUSE DAMAGE AND/OR PERSONAL INJURY AND WILL INVALIDATE THE WARRANTY. KEEP THESE INSTRUCTIONS SAFE FOR FUTURE USE.



Refer to instructions



Wear eye protection



Wear protective gloves



Wear safety footwear



Wear ear protection



Electrical shock hazard



Wear Correct Face mask



Keep in dry area protect from rain

1. SAFETY

1.1. Electrical Safety

- ❑ **WARNING!** It is the user's responsibility to check the following:
 - Check all electrical equipment and appliances to ensure that they are safe before using. Inspect power supply leads, plugs and all electrical connections for wear and damage. Sealey recommend that an RCD (Residual Current Device) is used with all electrical products. You may obtain an RCD by contacting your local Sealey dealer.
 - if the used in the course of business duties, it must be maintained in a safe condition and routinely PAT (Portable Appliance Test) tested.
- ✓ Electrical safety information, it is important that the following information is read and understood.
- ✓ Ensure that the insulation on all cables and on the appliance is safe before connecting it to the power supply.
- ✓ Regularly inspect power supply cables and plugs for wear or damage and check all connections to ensure that they are secure.
- ✓ Ensure that the voltage rating on the appliance suits the power supply to be used and that the plug is fitted with the correct fuse - see fuse rating in these instructions.
- ✗ **DO NOT** pull or carry the appliance by the power cable.
- ✗ **DO NOT** pull the plug from the socket by the cable. Remove the plug from the socket by maintaining a firm grip on the plug.
- ✗ **DO NOT** use worn or damaged cables, plugs or connectors. Ensure that any faulty item is repaired or replaced immediately by a qualified electrician.

This product is fitted with a BS1363/A 13 Amp 3 pin plug.

If the cable or plug is damaged during use, switch the electricity supply and remove from use.

Replace a damaged plug with a BS1363/A 13 Amp 3 pin plug. If in doubt contact a qualified electrician.

Class II products are wired with live (brown) and neutral (blue) only are marked with the Class II symbol;

A) Connect the BROWN live wire to the live terminal 'L'.

B) Connect the BLUE neutral wire to the neutral terminal 'N'.

C) After wiring, check that there are no bare wires and ensure that all wires have been correctly connected.



Ensure that the cable outer sheath extends inside the cable restraint and that the restraint is tight.

- ✗ **DO NOT** connect either wire to the earth terminal.
- Sealey recommend that repairs are carried out by a qualified electrician.

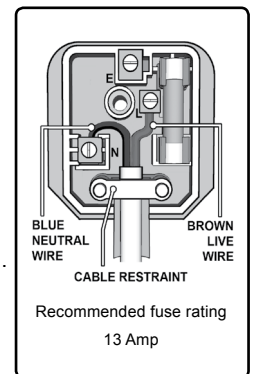

1.2. General Safety

- ✓ Disconnect the drill from the mains power before changing accessories, servicing or performing any maintenance.
- ✓ Maintain drill in good condition. Check moving parts and alignment, and keep drill bits sharp. If necessary use an authorised service agent.
- ✓ Replace or repair damaged parts. *Use recommended parts only. Unauthorised parts may be dangerous and will invalidate the warranty.*
- ✓ Wear approved safety eye protection with side shields, and a dust mask if drilling generates dust. Rubber gloves are recommended when using outdoors, and safety gloves when drilling items such as steel, brickwork etc,
- ✓ Remove ill fitting clothing. Remove ties, watches, rings, and other loose jewellery, and contain long hair.
- ✓ Use drill in an adequate working area for its function, keep area clean, tidy and free from unrelated materials, and ensure adequate lighting.
- ✓ Prevent body contact with grounded surfaces to avoid electric shock i.e. pipes, radiators, ranges, refrigerators etc.
- ✓ Evaluate your working area before using the drill i.e. ceiling, floors and enclosures may contain hidden electrical wires or water piping.
- ✓ Maintain correct balance and footing. **DO NOT** over-reach and ensure the floor is not slippery and wear non-slip shoes.
- ✓ The supplementary handle grip should always be attached for use.
- ✓ Keep children and unauthorised persons away from the working area.
- ✓ Secure unsecured workpiece with a clamp, vice or other adequate holding device. **DO NOT** hold unsecured work in your hand.
- ✓ Avoid unintentional starting, and ensure the lock-on button is disengaged before use.
- ✗ **DO NOT** use the drill for a task it is not designed to perform.
- ✗ **DO NOT** operate drill where there are flammable liquids or gasses.

- ✗ **DO NOT** get the drill wet or use in damp or wet locations.
- ✗ **DO NOT** operate the drill if any parts are missing or the drill is damaged, as this may cause failure and/or possible personal injury.
- ✗ **DO NOT** operate the drill when you are tired or under the influence of alcohol, drugs or intoxicating medication.
- ✗ **DO NOT** carry the drill with your finger on the power switch, or carry by the power cord, or leave the drill running whilst unattended.
- ✓ When not in use, switch drill off, remove plug from power supply, clean the drill and store in safe, dry, childproof location.

2. INTRODUCTION

750W Hammer drill with variable speed and reverse controls. Suitable for driving and removing screws. Hammer action allows up to 13mm capacity in masonry. Features high quality chuck, textured grip handle and is supplied with adjustable side handle, 2mtr cable and plug.

3. SPECIFICATION

Model No.....	SD750
Capacity.....	Ø13mm
Motor Power.....	750W
Supply.....	230V
No Load Speed.....	0-3000rpm
Hammer Action.....	45000bpm
Drilling Capacities:	
Wood.....	Ø20mm
Steel.....	Ø10mm
Masonry.....	Ø13mm
Weight.....	2.0kg

4. OPERATION

1. Trigger lock Button
2. Trigger
3. Variable Speed Knob
4. Forward / Reverse Switch
5. Drill / Impact Switch
6. Chuck
7. Depth Gauge
8. Side Handle
9. Chuck Key Holder

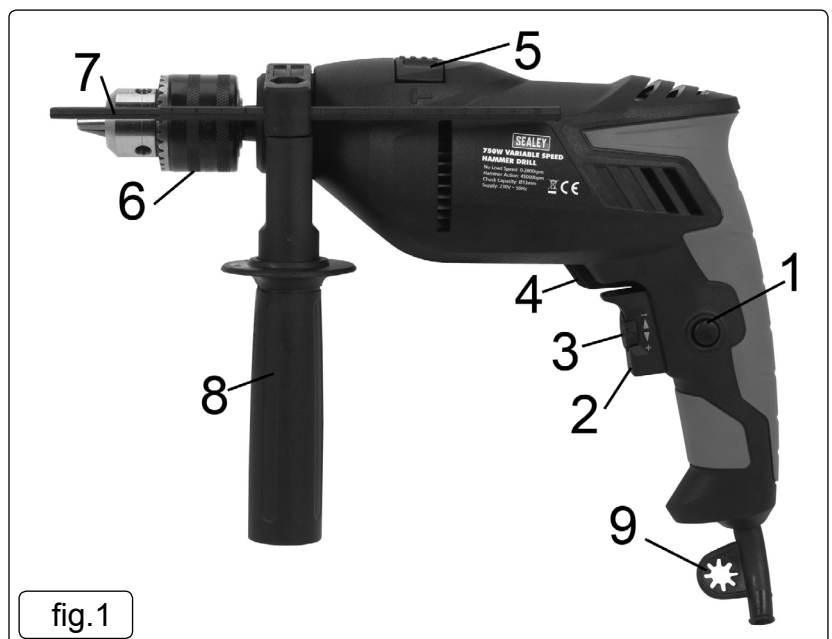

fig.1

4.1. Preparing Drill for Use.

- 4.1.1. Ensure the drill is switched off and unplugged from the power supply.
- 4.1.2. Fitting the side handle. (fig.1.8) Fit side handle grip by placing the handle assembly over the chuck and onto the machine neck. Secure by rotating the handle clockwise until it is tight and the handle can no longer be moved. To ensure a good grip in all circumstances, the angle of the handle may be changed by rotating the handle grip anticlockwise until the handle assembly is loose. Rotate the handle to the desired angle and re-tighten.
- 4.1.3. Fitting the depth gauge. (fig.1.7) To fit the depth gauge loosen the side handle and pass the gauge through the handle clamp to the required depth. Rotate the handle to the required angle. As the handle is tightened the depth gauge will also be gripped firmly.

4.2. Drill Controls

- 4.2.1. ON/OFF Variable speed trigger. The drill has a variable speed control On/Off trigger (fig.1.2) speed increases as the trigger is depressed. Adjacent to the trigger is a button that can be used to lock the trigger in the 'ON' position for continuous drilling.
 - 4.2.2. Trigger lock. (fig.1.1) To lock 'ON', depress the trigger, push in and hold the button then release the trigger. Release the lock-on button and the drill will continue running.
 - 4.2.3. To release the lock, depress the trigger and the lock releases.
 - 4.2.4. Power failure. If you have the lock-on feature engaged during use and the drill becomes disconnected from the power supply, make sure that the lock is released, before reconnecting to the power supply.
- ☐ **WARNING!** Before connecting the drill to a power supply, ensure it is not in the lock-on position as this may result in damage and personal injury. Depress the trigger to ensure release. **DO NOT** use the lock-on facility for jobs where the drill may need to be stopped suddenly.
- 4.2.5. Maximum speed setting control. The variable speed trigger has a small rotating knob incorporated into it (figs.1.3) which can be used to control the maximum speed of the drill. When the knob is set to the maximum or + setting the trigger can be fully depressed allowing the drill to turn at its maximum speed. As the knob is turned towards the minimum or - setting, the movement of the trigger is restricted so that the drill will turn at a lower pre-set speed when the trigger is depressed. This facility is useful when working with materials that should be drilled at a constant, lower speed.
 - 4.2.6. The required speed will depend on the material and task in hand. The following may be used as a general guide.
 - a) Low speeds are recommended for hard materials, i.e. stone, ceramic, concrete, high tensile steel, and tasks such as starting holes without centre punch, driving screws, mixing paint etc.
 - b) Medium speeds are suitable for plastics and laminates.

- c) High speeds recommended for soft materials such as wood, aluminium, copper, bronze and brass.
- WARNING! DO NOT** run the drill at low to medium speeds for extended periods of time as this may cause drill to overheat. To cool drill, run it without a load, at full speed, for a few seconds.
- 4.2.7. Direction of rotation. Select either forward or reverse rotation using the lever mounted directly above the trigger (figs.1.4). Select reverse by moving the lever towards the 'L' symbol and forward by moving the lever adjacent to the 'R' symbol and the trigger lock button.
- WARNING! DO NOT** attempt to change direction of rotation whilst the drill is still running.
- 4.2.8. Selection of hammer action / drilling. When using a masonry drill bit, the hammer action can be used to assist penetration into concrete, stone and masonry. The hammer action selector is a large sliding 'switch' situated on top of the drill. To select hammer action slide the selector to the left so that it is adjacent to the hammer symbol moulded on the side of the case. To disable the hammer action slide the switch in the other direction to be adjacent to the drill symbol moulded on the casing.
- 4.3. **Drill or Tool Bit Fitting.**
- WARNING!** Unplug from the mains power supply before placing bit into chuck. Adjust the chuck jaws to a point where the opening is slightly larger than the drill/tool bit to be used. Also raise the front of the drill slightly to stop the bit from falling out of the chuck jaws. Insert the drill/tool bit into the chuck. Place the chuck key in one of the chuck holes and tighten the chuck fully by turning the chuck key clockwise.
- 4.4. **Depth Stop Gauge.** Ensure the work piece has a flat surface and is wide enough for the gauge to butt up against it when the required depth has been reached. Measure back from the tip of the drill bit to the point at which the drill must stop. Release clamp/handle and extend the depth gauge to the point at which you wish to stop drill penetrating further and righten the handle/clamp. Once the drill has reached the correct depth, the gauge will butt up against the work piece and stop further inward progress.
- 4.5. **Standard Drilling Instructions.**
- WARNING!** Ensure you wear approved safety goggles and any other safety item required for the job. Remove the chuck key before using the drill, and ensure the trigger button lock is not locked in position which would result in accidental starting of the drill. Ensure drill is unplugged from the mains power supply.
- 4.5.1. If the material to be drilled is free standing it should be secured in a vice or with clamps to keep it from turning as the drill bit rotates.
- 4.5.2. When drilling metals, use a light oil on the drill bit to keep it from overheating. Oil will prolong life of the drill bit and improve the drilling action.
- 4.5.3. For hard smooth surfaces use a centre punch to mark desired hole location. This will prevent bit from slipping as drilling is started.
- 4.5.4. A pilot hole may be necessary to assist the final drill size through the work piece. Lock a pilot drill (smaller size drill than the finished hole size) into the chuck. Follow steps 4.5.5 to 4.5.7. below and drill a pilot hole in the middle of the centre punch mark where final hole is to be drilled. Insert the final sized bit. Hold drill firmly and place the bit at the entrance of the pilot hole and depress the trigger.
- 4.5.5. Plug drill into mains power supply.
- 4.5.6. Hold tool firmly and place the drill bit tip to the point to be drilled.
- 4.5.7. Depress the trigger to start drill. Move the drill bit into the work piece, applying only enough pressure to keep the bit cutting.
 - × **DO NOT** force or apply side pressure, which will elongate the hole.
 - WARNING!** Be prepared for drill binding or break through. When these situations occur the drill has a tendency to grab and kick in the opposite direction and could cause loss of control. If you are not prepared, this loss of control could result in damage and/or personal injury.
- 4.5.8. If the drill bit jams in the work piece or if the drill stalls, release the trigger switch immediately. Remove the drill bit from the work piece and determine the reason for jamming, before recommencing drilling.
- 4.5.9. For continuous operation, depress the trigger lock.
- 4.5.10. The depth gauge may be used to pre-determine the depth of hole.
- 4.5.11. After working for a lengthy period of time at low speed setting, run drill for a few seconds with no load, at high speed.
 - WARNING!** Drill bits become very hot during use. Allow to cool or hold with a cloth for removal.
- 4.5.12. When work is complete, unplug from the mains power supply, remove the drill bit / tool bit from the chuck, clean drill, clean and if necessary sharpen the tool bit, and store drill in a safe, dry childproof location.

5. MAINTENANCE

- 5.1. **Changing the drill chuck.**
To remove the drill chuck, open the chuck fully. Locate the internal screw head and undo by turning the screw CLOCKWISE (left handed thread). Stop the chuck from moving by securing the nut at the base of the chuck with a spanner. To replace the chuck reverse the above procedure.
- 5.2. **Cleaning the drill.**
Keep the drill ventilation slots clean and free from obstructions. If available, blow compressed air into the vents to clear any internal dust (safety goggles must be worn when undertaking this process). Keep the outer case of the drill clean and free from grease
 - × **DO NOT** wash with water, use solvents or abrasives.

WARNING! – Risk of Hand Arm Vibration Injury.

This tool may cause Hand Arm Vibration Syndrome if its use is not managed adequately.

This tool is subject to the vibration testing section of the Machinery Directive 2006/42/EC.

This tool is to be operated in accordance with these instructions.

Measured vibration emission value (a):14.857 m/s²

Uncertainty value (k):1.5 m/s²

Please note that the application of the tool to a sole specialist task may produce a different average vibration emission. We recommend that a specific evaluation of the vibration emission is conducted prior to commencing with a specialist task.

A health and safety assessment by the user (or employer) will need to be carried out to determine the suitable duration of use for each tool.

NB: Stated Vibration Emission values are type-test values and are intended to be typical.

Whilst in use, the actual value will vary considerably from and depend on many factors.

Such factors include; the operator, the task and the inserted tool or consumable.

NB: ensure that the length of leader hoses is sufficient to allow unrestricted use, as this also helps to reduce vibration.

The state of maintenance of the tool itself is also an important factor, a poorly maintained tool will also increase the risk of Hand Arm Vibration Syndrome.

Health surveillance.

We recommend a programme of health surveillance to detect early symptoms of vibration injury so that management procedures can be modified accordingly.

Personal protective equipment.

We are not aware of any personal protective equipment (PPE) that provides protection against vibration injury that may result from the uncontrolled use of this tool. We recommend a sufficient supply of clothing (including gloves) to enable the operator to remain warm and dry and maintain good blood circulation in fingers etc. Please note that the most effective protection is prevention, please refer to the Correct Use and Maintenance section in these instructions. Guidance relating to the management of hand arm vibration can be found on the HSC website www.hse.gov.uk - Hand-Arm Vibration at Work.

Parts support is available for this product. To obtain a parts listing and/or diagram, please log on to www.sealey.co.uk, email sales@sealey.co.uk or telephone 01284 757500.



Environmental Protection

Recycle unwanted materials instead of disposing of them as waste. All tools, accessories and packaging should be sorted, taken to a recycling centre and disposed of in a manner which is compatible with the environment. When the product becomes completely unserviceable and requires disposal, drain off any fluids (if applicable) into approved containers and dispose of the product and the fluids according to local regulations.



WEEE Regulations

Dispose of this product at the end of its working life in compliance with the EU Directive on Waste Electrical and Electronic Equipment (WEEE). When the product is no longer required, it must be disposed of in an environmentally protective way. Contact your local solid waste authority for recycling information.

NOTE: It is our policy to continually improve products and as such we reserve the right to alter data, specifications and component parts without prior notice.

IMPORTANT: No liability is accepted for incorrect use of this product.

WARRANTY: Guarantee is 12 months from purchase date, proof of which will be required for any claim.



Sole UK Distributor, Sealey Group.
Kempson Way, Suffolk Business Park,
Bury St. Edmunds, Suffolk.
IP32 7AR



01284 757500



01284 703534



www.sealey.co.uk



sales@sealey.co.uk