





6. TROUBLESHOOTING

A faulty spray is usually caused by improper cleaning or dried material around the fluid nozzle tip or in the air nozzle. Soak these parts in a solvent that will soften the dried material and remove with a brush or a cloth. Never use metal instruments to clean the air or fluid nozzles. These parts are carefully machined and any damage to them will cause a faulty spray. If either the air nozzle or fluid nozzle is damaged, the part must be replaced before a perfect spray can be obtained.

VIEW OF PROBLEM	POSSIBLE REASON FOR PROBLEM	SOLUTION
	Dried material in a dirty side port restricts passage of air. Greater flow of air from the cleaner side port forces a fan pattern in the direction of the clogged side.	Dissolve material in the side ports with solvent, then blow the gun clean. Do not poke into the opening with metal instruments.
	Dried material around the outside of the fluid nozzle tip restricts the passage of atomizing air at one point through the centre opening of the air nozzle and results in the pattern shown. This pattern can also be caused by a loose air nozzle.	Remove the air nozzle and wipe off fluid tip using a rag dampened with solvent. Tighten the air nozzle
	Material too thin or atomization air pressure too high.	Regulate material viscosity or reduce air pressure
	Dirt between the fluid nozzle seat and body or loosely installed fluid nozzle will cause the gun to spit.	Remove the fluid nozzle, clean the back of the nozzle and the nozzle seat in the gun body using a rag dampened with thinner. Replace the nozzle and secure it tightly against the body.
Material bubbles or "boils" in paint cup.	Atomised air flowing through the paint channel to pot. The paint nozzle is not tight enough. Air nozzle is not completely screwed in. The air net clogged and the seat is defective or nozzle insert is damaged.	Tighten, clean or replace parts accordingly.

7. PARTS LIST

Issue : 2
Date: 11/08/08

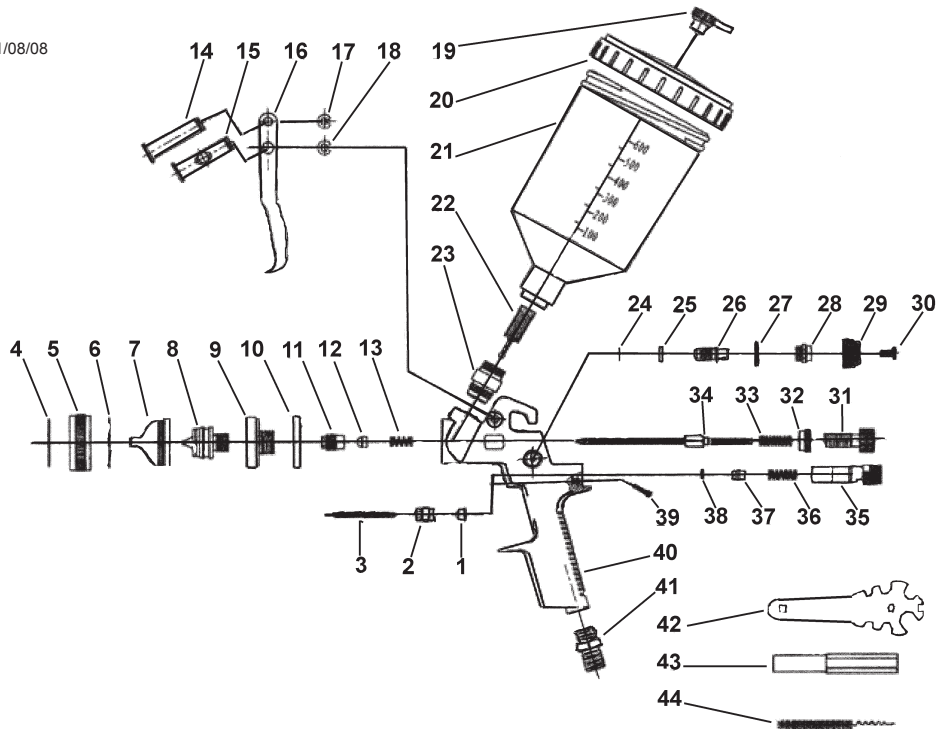

ITEM	PART NO.	DESCRIPTION	ITEM	PART NO.	DESCRIPTION	ITEM	PART NO.	DESCRIPTION
1	S701G.01	SEAL WASHER	17	S701G.17	SNAP RETAINER	33	S701G.33	FLUID NEEDLE SPRING
2	S701G.02	SWITCH KNOB	18	S701G.18	SNAP RETAINER	34	S701G.34	FLUID ADJ. NEEDLE
3	S701G.03	SWITCH POLE	19	S701G.21	CONTAINER ASS'Y (PARTS 19, 20, 21, 22)	35	S701G.35	MODULATOR
4	S701G.04	AIR CAP ASS'Y (PARTS 04, 05, 06 07)	23	S701G.23	ADAPTER	36	S701G.36	SWITCH SPRING
8	S701G.08	FLUID NOZZLE	24	S701G.24	SNAP RETAINER	37	S701G.37	SWITCH BLOCK
9	S701G.09	FLUID NOZZLE PLUG	25	S701G.25	O- RING	38	S701G.38	O-RING
10	S701G.10	WASHER	26	S701G.26	PATTERN ADJ	39	S701G.39	SCREW
11	S701G.11	DIRECTION SCREW	27	S701G.27	COPPER WASHER	40	S701G.40	GUN BODY
12	S701G.12	WASHER	28	S701G.28	PATTERN ADJ KNOB	41	S701G.41	AIR INLET PLUG
13	S701G.13	SPRING	29	S701G.29	PATTERN ADJ SCREW	42	S701G.42	TOOL WRENCH
14	S701G.14	TRIGGER PIN 1	30	S701G.30	SCREW	43	S701G.43	HEX WRENCH
15	S701G.15	TRIGGER PIN 2	31	S701G.31	FLUID ADJ. KNOB	44	S701G.44	BRUSH
16	S701G.16	TRIGGER	32	S701G.32	JOINT CAP			

NOTE: It is our policy to continually improve products and as such we reserve the right to alter data, specifications and component parts without prior notice.

IMPORTANT: No liability is accepted for incorrect use of product.

WARRANTY: Guarantee is 12 months from purchase date, proof of which will be required for any claim.

INFORMATION: For a copy of our latest catalogue and promotions call us on 01284 757525 and leave your full name and address, including postcode.



Sole UK Distributor
Sealey Group,
Bury St. Edmunds, Suffolk.



01284 757500



01284 703534

E-mail: sales@sealey.co.uk
Web: www.sealey.co.uk