

ITEM	PART NO	DESCRIPTION
1	PX90M-01	COVER HOUSING
2	PX90-49	RELEASE BUTTON
3	PX90-49-1	SPRING
4	PX90-06	FLUID INLET COUPLER
5	PX90-14	O-RING
6	PX90-05	FLUID OUTLET HOUSING
7	PX90-32	O-RING
8	PX90-09	LOCK NUT
9	PX90-49-6	LOCK BUSHING
10	PX90-49-3	SHAFT
11	PX90-49-5	SPRING
12	PX90-51	CHECK VALVE
13	PX90M-13	SAFETY CAP
14	PX90-49-5	SPRING
15	PX90M-15	BRACKET BASE
16	PX90M-16	ARM
17	PX90-13	O-RING
18	PX90-02	RESERVOIR TANK
19	PX55-19	PIN
20	PX55-25	SCREW
21	PX55-20	FLOAT
22	PX90-04	TUBE STORAGE UNIT
23	PX90-03	BASE
24	PX90-34	SCREW M6x15
25	PX90-11	FOOTBOARD
26	PX90-12	FIXED STRIP
27	PX90-35	SCREW M4x10
28	PX90-36	SCREW M8x16
29	PX90M-29	SEAL RING
30	PX90-18	SHAFT
31	PX90-28	OIL SEAL
32	PX90-27	HOLDER
33	PX90-47	FLAT WASHER
34	PX90-46	PISTON SPACER
35	PX90-45	PISTON
36	PX90-44	HEX NUT M8
37	PX90-19	HOLDER
38	PX90M-17	ALUMINIUM TUBE
39	PX90M-23	ALUMINIUM TUBE BASE
40	PX90-38	SCREW M5x16
41	PX90-39	NUT M5
42	PX90-16	HANDLE
43	PX90-20	CAP
44	PX90-43	SCREW M5x20
45	PX90-30	MAIN SUCTION TUBE (c/w ADAPTOR)
46	PX90-31	EXTRACTING TUBE (c/w ADAPTOR)
48	PX90-29	BRAKE TUBE (c/w RUBBER FITTING)

Issue: 1
 Issue Date: 100507

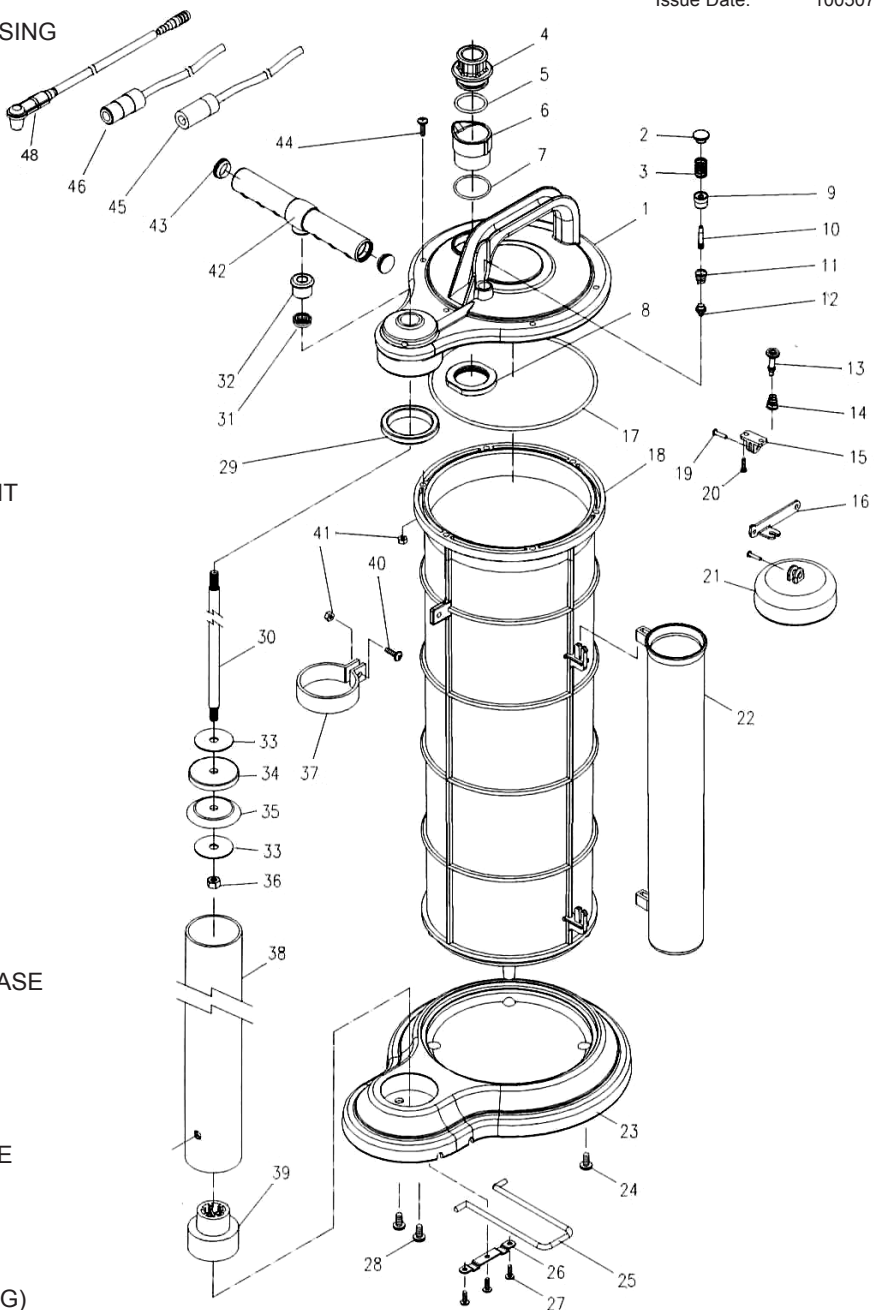

NOTE: It is our policy to continually improve products and as such we reserve the right to alter data, specifications and component parts without prior notice.

IMPORTANT: No liability is accepted for incorrect use of product.

WARRANTY: Guarantee is 12 months from purchase date, proof of which will be required for any claim.

INFORMATION: For a copy of our latest catalogue and promotions call us on 01284 757525 and leave your full name and address, including postcode.