



INSTRUCTIONS FOR:

HIGH LEVEL AXLE STAND 7TONNE CAPACITY - COMMERCIAL USE

MODEL NO: **ASC70**

Thank you for purchasing a Sealey product. Manufactured to a high standard this product will, if used according to these instructions and properly maintained, give you years of trouble free performance.

IMPORTANT: PLEASE READ THESE INSTRUCTIONS CAREFULLY. NOTE THE SAFE OPERATIONAL REQUIREMENTS, WARNINGS, AND CAUTIONS. USE THIS PRODUCT CORRECTLY AND WITH CARE FOR THE PURPOSE FOR WHICH IT IS INTENDED. FAILURE TO DO SO MAY CAUSE DAMAGE AND/OR PERSONAL INJURY AND WILL INVALIDATE THE WARRANTY.



Refer to instruction manual

1. SAFETY

- ✓ Ensure the axle stands are assembled complete and all fixings are secured. **DO NOT** use if any component is damaged.
 - ✓ Raise the sprung assisted centre column of the axle stand and ensure the centre of the saddle is located under a structurally sound vehicle jacking point. Refer to the vehicle handbook for jacking points.
 - ☐ **WARNING!** Caution required when removing the centre column retaining pin; internal spring forces will be encountered.
 - ▲ **DANGER!** Great care must be taken to ensure you lower the vehicle slowly and carefully onto the centres of all the axle stands simultaneously. Achieved using the fine adjusters.
 - ✓ Ensure that the vehicle and stands are stable before starting work.
 - x **DO NOT** use on soft ground or tarmacadam. Use on horizontal concrete only.
 - ✓ Use a minimum of four stands to support and stabilise a vehicle, and a minimum of two additional stands for each additional axle.
 - x **DO NOT** support more than the maximum capacity, as written on the axle stand, (i.e. 14 tonnes *per pair etc.*).
 - x **DO NOT** apply side horizontal forces to the vehicle while supported by the stands.
 - x **DO NOT** start the engine while the vehicle is supported by the stands.
 - ✓ Use only supplied attachments, restraints or adaptors supplied by the manufacturer.
- ☐ **WARNING! The warnings, cautions and instructions in this manual cannot cover all possible conditions and situations that may occur. It must be understood by the operator that common sense and caution are factors which cannot be built into this product, but must be applied by the operator.**

2. INTRODUCTION

Heavy-duty high level axle stand to safely support vehicle for extended period of time. Independently UK load tested. Supplied with three interchangeable crutches for even load support. Heavy gauge steel frame and welded construction give superior strength and safety. Features captive, spring assisted, multi-position pin load support and castors for easy manoeuvrability. Ideal for commercial vehicles. Sold as singles.

3. SPECIFICATION

Model No:	ASC70
Capacity Each:	7tonne
Capacity Pair:	14tonne
Minimum Height:	1295mm
Maximum Height:	1905mm

N.B. IN ORDER TO OBTAIN THE CAPACITIES SHOWN, THE VEHICLE MUST BE EVENLY SUPPORTED BY THE STANDS.

WARNING!

DO NOT OVERLOAD AXLE STANDS BEYOND RATED CAPACITY. OVERLOADING CAN CAUSE DAMAGE TO, OR FAILURE OF, THE AXLE STANDS. POSITION LOAD ON CENTRE OF SADDLE. ALWAYS USE STANDS IN PAIRS ON HARD LEVEL SURFACE CAPABLE OF SUSTAINING THE LOAD. USE OF STANDS ON OTHER THAN HARD LEVEL SURFACES CAN RESULT IN LOAD INSTABILITY AND POSSIBLE LOSS OF LOAD. DO NOT USE ON TARMACADAM. FAILURE TO FOLLOW THESE INSTRUCTIONS, MAY RESULT IN DAMAGE TO AXLE STANDS, LOSS OF LOAD RESULTING IN PROPERTY DAMAGE, SERIOUS PERSONAL INJURY OR LOSS OF LIFE.

4. CONTENTS

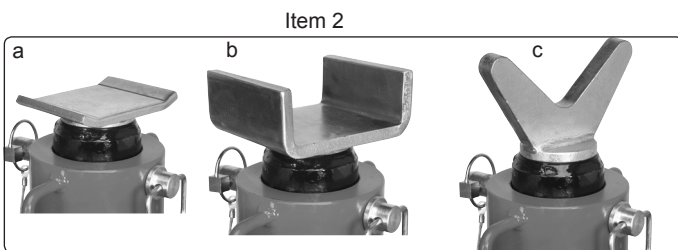

Item	Description	Qty
1	Central Column Sub Assembly	1-set
2a,b,c	Saddles	1-set
3	Tripod Leg	3
4	Swivel Castor Sub Assembly	3
5	Cross Members	3
6	Bracket	3
7	Hexagon Screw M12 X 40	9
8	Hexagon Bolt M12 X 75	3
9	Hexagon Nut M12	12
10	Plain Washer Ø12	24
11	Spring Washer Ø12	12

4. ASSEMBLY

Assembly will require two persons. The central column will be partially assembled with a tube fully inserted against the forces of an internal compression spring. **▲ It is important to leave this tube inserted and pinned as supplied at this stage.**

- 4.1. Offer the three tripod legs (item 5) into the central column pockets (item 1).
- 4.2. Fit loosely the three cross members (item 5) to the tripod legs with fixings (items 7,9,10,11)
- 4.3. Fit loosely the three brackets (item 6) to the tripod legs with fixings (items 8,9,10,11) and the central column ring with fixings (items 7,9,10,11).
- 4.4. Tighten all fixings to form a rigid geometrically aligned frame.

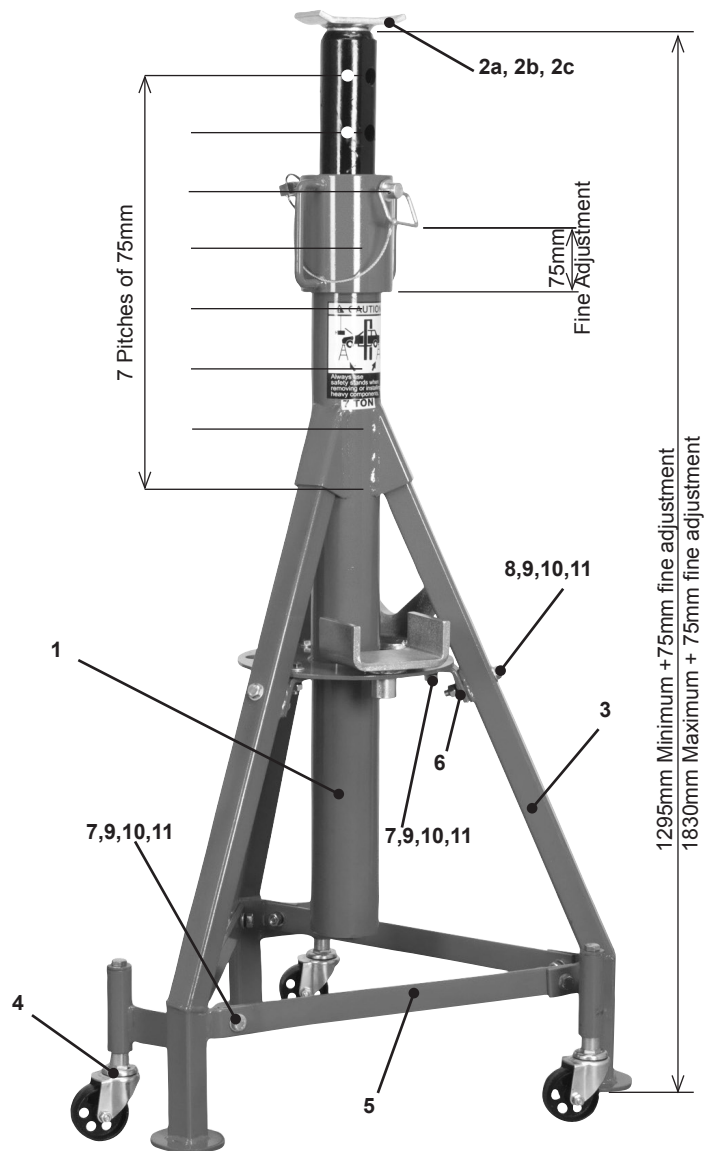
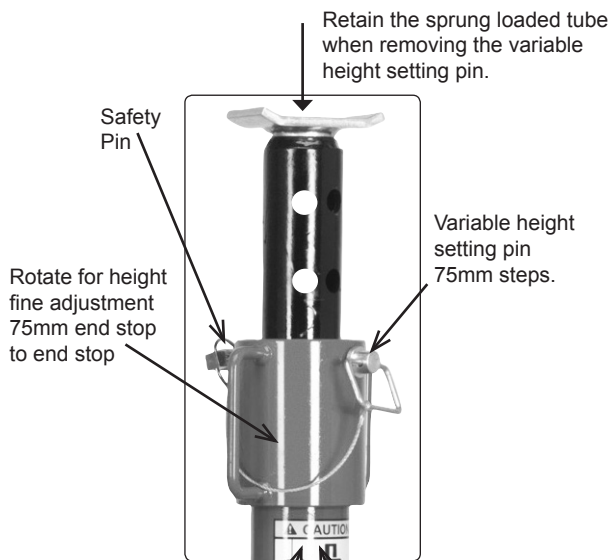

5. OPERATION

- 5.1. It is the responsibility of the owner to ensure that the operator has read these instructions together with the safety features on the side of the stand and that the operator is familiar with the stands use and limitations.
 - 5.1.2. Elevate the vehicle to the required working height and position a minimum of four stands with appropriate saddles beneath the vehicle manufacturer's recommended jacking/support positions.
 - 5.1.3. For large movement of the the column tube it will be necessary to retain it by hand whilst withdrawing the height setting pin. Allow the column tube to elevate assisted by the spring to the nearest available pin hole prior to engaging with the vehicle. Ensure the pin is inserted fully and safety pinned, then rotate the fine adjuster to close the gap to zero at all locations.
 - 5.1.4. With all stands stable, slowly lower the vehicle to be fully supported by the vehicle stand.

6. MAINTENANCE

- 6.1. Before each use or after an abnormal load or shock, check that stands and stand welds are not cracked and that there are no missing or damaged parts, including fixings. *Any suspect axle stands must be removed from service immediately. An annual inspection of the unit is recommended to be carried out by the supplier's authorised repair facility.*
- 6.2. Periodically lubricate the fine adjuster thread with a light general purpose oil.
- 6.3. After use, wipe clean the stand and saddles, return the saddles to the storage ledge. Store indoors.



Environmental Protection.

Recycle unwanted materials instead of disposing of them as waste. All tools, accessories and packaging should be sorted, taken to a recycle centre and disposed of in a manner which is compatible with the environment.

NOTE: It is our policy to continually improve products and as such we reserve the right to alter data, specifications and component parts without prior notice.

IMPORTANT: No liability is accepted for incorrect use of this product.

WARRANTY: Guarantee is 12 months from purchase date, proof of which will be required for any claim.



Sole UK Distributor, Sealey Group,
Kempson Way, Suffolk Business Park,
Bury St. Edmunds, Suffolk,
IP32 7AR

01284 757500

www.sealey.co.uk

01284 703534

sales@sealey.co.uk