

Thank you for purchasing a Sealey product. Manufactured to a high standard this product will, if used according to these instructions and properly maintained, give you years of trouble free performance.



IMPORTANT: PLEASE READ THESE INSTRUCTIONS CAREFULLY. NOTE THE SAFE OPERATIONAL REQUIREMENTS, WARNINGS & CAUTIONS. USE THE PRODUCT CORRECTLY AND WITH CARE FOR THE PURPOSE FOR WHICH IT IS INTENDED. FAILURE TO DO SO MAY CAUSE DAMAGE AND/OR PERSONAL INJURY AND WILL INVALIDATE THE WARRANTY. PLEASE KEEP INSTRUCTIONS SAFE FOR FUTURE USE.

1. SAFETY INSTRUCTIONS

- ✓ Maintain the jack in good condition (use an authorised service agent).
 - ✓ Replace or repair damaged parts. *Use genuine parts only. Unauthorised parts may be dangerous and will invalidate the warranty.*
 - ✓ Locate the jack in a suitable work area. Keep area clean and tidy and free from unrelated materials and ensure that there is adequate lighting. Also ensure that the floor is level and strong enough (preferably concrete) to take the weight of the jack and the transmission unit. **DO NOT** operate the jack on tarmac, as the surface may be unstable.
 - ✓ Keep the jack clean for best and safest performance.
 - ✓ The maximum transmission unit weight is 150kg. **DO NOT** exceed this rated capacity.
 - ✓ Remove ill fitting clothing. Remove ties, watches, rings and other loose jewellery and contain long hair.
 - ✓ Keep hands and fingers clear of the scissor mechanism during use.
 - ✓ Maintain correct balance and footing, **DO NOT** over reach. Ensure that the floor is not slippery and wear non-slip shoes.
 - ✓ Keep children and unauthorised persons away from the work area.
 - x **DO NOT** use the jack for a task it is not designed to perform.
 - x **DO NOT** use the jack as a vehicle lifting device.
 - x **DO NOT** operate the jack if damaged.
 - x **DO NOT** operate the jack when you are tired or under the influence of alcohol, drugs or intoxicating medication.
 - x **DO NOT** allow untrained persons to operate the jack.
 - x **DO NOT** make any modifications to the jack.
 - ✓ Before storing, ensure that all parts are clean and the jack is fully lowered. Store jack in a safe, dry, childproof area.
- **WARNING! The warnings, cautions and instructions referred to in this manual cannot cover all possible conditions and situations that may occur. It must be understood that common sense and caution are factors which cannot be built into this product, but must be applied by the operator.**

2. INTRODUCTION & SPECIFICATION

- Suitable for raising and lowering gearbox and differential units.
- Easy to operate scissor mechanism for precision when fitting the transmission unit.
- The saddle is fitted with a webbing strap with metal roller buckle to hold the load securely and has a 5° tilt adjustment.
- Four heavy-duty castors provide flexibility of movement within the workplace.

Model No: TJ150E
 Capacity: 150kg
 Minimum Saddle Height: 195mm
 Maximum Saddle Height: 585mm
 Base Dimensions: 400 x 420mm
 Ratchet Drive Socket Size: ½" Square

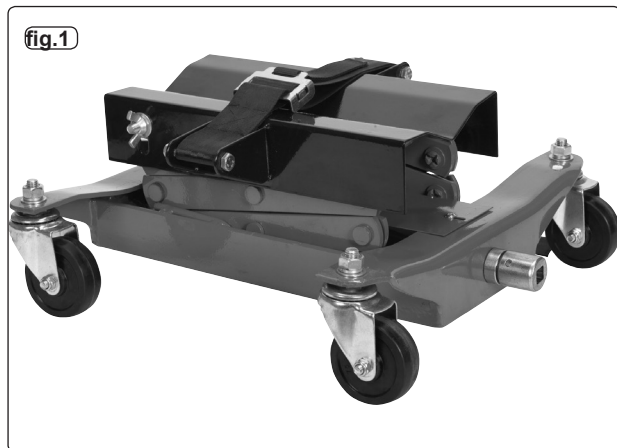

3. OPERATING INSTRUCTIONS

Refer to **fig.2**.

- 3.1. Ensure that the vehicle being worked on is securely immobilised. If any wheels are removed it **MUST** be supported securely on axle stands. **NEVER WORK UNDER A VEHICLE SUPPORTED BY A JACK ONLY.**
- 3.2. Unfasten the webbing strap and roll the jack to immediately below the unit to be removed.
- 3.3. Using a ½" ratchet drive inserted into the drive socket, raise the saddle into light contact with the load.
DO NOT use an impact wrench with this product.
- 3.4. The saddle may be tilted by up to 5° to allow better registration with the transmission unit being removed. Slacken the wingnuts on both sides to allow adjustment of the saddle and re-tighten to lock in position. **DO NOT** attempt to adjust tilt whilst under load.

- 3.5. Secure the transmission unit to the saddle using the webbing strap and remove fastenings holding the transmission unit to the vehicle. It may be necessary to manoeuvre the jack gently to allow the fastenings to be withdrawn cleanly.
- 3.6. When the transmission unit is free, reverse the ratchet to lower the saddle allowing removal from beneath the vehicle.
- 3.7. It is recommended that, for maximum stability, the saddle is lowered fully before moving under load.
- 3.8. Re-installation is the reverse of the above procedure.

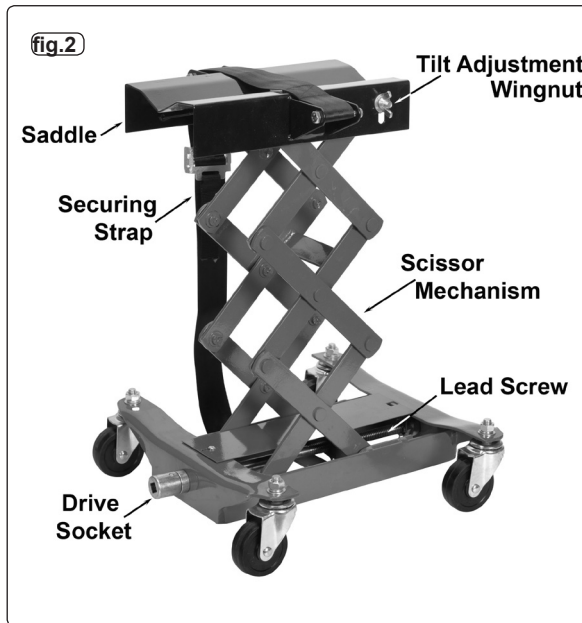

4. MAINTENANCE

- 4.1. Apply a good-quality grease periodically to all moving parts, paying particular attention to the lead screw (fig.2).
- 4.2. Replace the securing strap if it becomes torn or damaged in any way.

NOTE: It is our policy to continually improve products and as such we reserve the right to alter data, specifications and component parts without prior notice.

IMPORTANT: No liability is accepted for incorrect use of this product.

WARRANTY: Guarantee is 12 months from purchase date, proof of which will be required for any claim.

INFORMATION: For a copy of our latest catalogue and promotions call us on 01284 757525 and leave your full name and address, including postcode.



Sole UK Distributor, Sealey Group,
Kempson Way, Suffolk Business Park,
Bury St. Edmunds, Suffolk,
IP32 7AR



01284 757500

01284 703534



www.sealey.co.uk

sales@sealey.co.uk