

INSTRUCTIONS FOR:
INFRARED LASER THERMOMETER
12:1

Model No: VS907

Thank you for purchasing a Sealey product. Manufactured to a high standard this product will, if used according to these instructions and properly maintained, give you years of trouble free performance.



IMPORTANT: PLEASE READ THESE INSTRUCTIONS CAREFULLY. NOTE THE SAFE OPERATIONAL REQUIREMENTS, WARNINGS AND CAUTIONS. USE THE PRODUCT CORRECTLY AND WITH CARE FOR THE PURPOSE FOR WHICH IT IS INTENDED. FAILURE TO DO SO MAY CAUSE DAMAGE AND/OR PERSONAL INJURY AND WILL INVALIDATE THE WARRANTY. PLEASE KEEP INSTRUCTIONS SAFE FOR FUTURE USE.

1. SAFETY INSTRUCTIONS

1.1. General Safety

- WARNING!** Ensure that Health & Safety, local authority and general workshop practice regulations are adhered to when using this equipment.
- WARNING! DO NOT** aim the laser beams at your or another person's or animal's eye and beware of reflections from mirrors or other shiny surfaces.
- ✓ Familiarise yourself with the applications, limitations, and potential hazards of the thermometer.
- ✓ Keep the thermometer clean and in good condition.
- ✓ Protect the thermometer from the following:
 - Electro-magnetic fields from engine components, arc welders and induction heaters closer than 125mm.
 - Static electricity.
 - Thermal shock caused by large and/or rapid ambient temperature change.
 - High temperatures.
- x **DO NOT** get the thermometer wet or use in damp or wet locations or areas where there is condensation.
- x **DO NOT** take readings through transparent materials such as glass or clear plastic. The surface temperature of these materials will be measured.
- x **DO NOT** use the thermometer in areas where there is steam, dust or smoke. These conditions will result in erroneous readings.
- x **DO NOT** use the thermometer for any purpose other than that for which it is designed.
- x **DO NOT** allow untrained persons (particularly children) to operate the thermometer.
- x **DO NOT** operate the thermometer when you are tired or under the influence of alcohol, drugs or intoxicating medication.



1.2. Laser Safety

The VS907 utilises a Class II laser that emits low levels of visible radiation (i.e. wavelengths between 400 and 700 nanometres) which are safe for the skin but not inherently safe for the eyes. The Class II emission limit is set at the maximum level for which eye protection is normally afforded by natural aversion responses to bright light. Accidental eye exposure is therefore normally safe, although the natural aversion response can be overridden by deliberately staring into the beam, and can also be influenced by the use of alcohol or drugs.

- WARNING! DO NOT** look or stare into the laser beam as permanent eye damage could result.
- ✓ Be aware that reflections of the laser beam from mirrors or other shiny surfaces can be as hazardous as direct eye exposure.



2. INTRODUCTION/SPECIFICATION

2.1. Introduction

High resolution laser thermometer that detects energy emission in the infrared spectrum and converts reading into a display of temperature. Features laser pointer, Maximum/Minimum/Average/Difference readings, data storage and data hold function, high/low alarm setup, auto power off. Temperature is displayed on a large 29mm LCD panel with back-lit display for use in low light areas. Temperature can be shown in either °C or °F. Powered by 9V cell (supplied). Storage case included.

2.2. Specification

Temperature Range	-50°C to +700°C (-58°F to +1292°F)
Accuracy	±5%
Response Time	500mSec
Focal Range	12:1
Operating Temperature	0°C to +40°C (+32°F to +104°F)
Storage Temperature	-20°C to +60°C (-4°F to +140°F)

3. SET UP

3.1. Installing/Changing Battery (fig.1)

- 3.1.1. On either side of the trigger, where the handle moulding meets the main body there are two very shallow recesses. Place thumb and finger into these recesses and pull the front section of the handle forward and down to reveal the battery compartment.
- 3.1.2. Attach the battery connector to the battery terminals and place the battery into the battery compartment making sure that the connection leads will not foul the cover when it is closed.
- 3.1.3. When the 'battery low' indicator appears on the display replace the battery immediately.

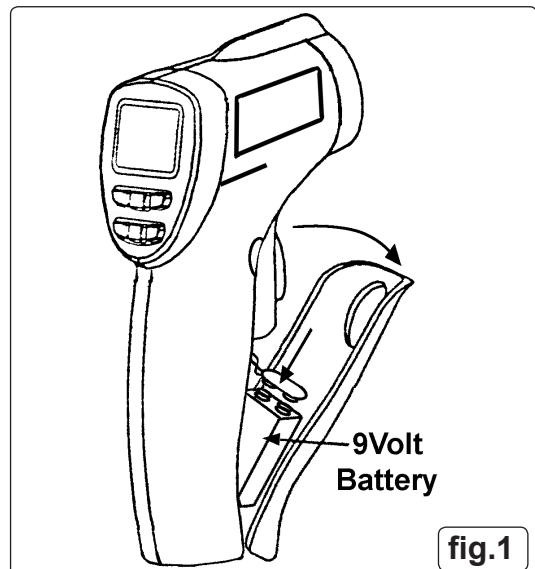

3.2. LCD Display (fig.2)

- A - Temperature Reading.
- B - Temperature Unit of Measurement indicator
- C - Laser On icon
- D - Backlight On icon
- E - Battery Status icon
- F - Scanning icon
- G - Data Hold icon
- H - Mode/Emissivity indicator
- I - Data Storage/Read icon
- J - Low Temperature Alarm icon
- K - High Temperature Alarm icon
- L - Set/Record Value Indicator

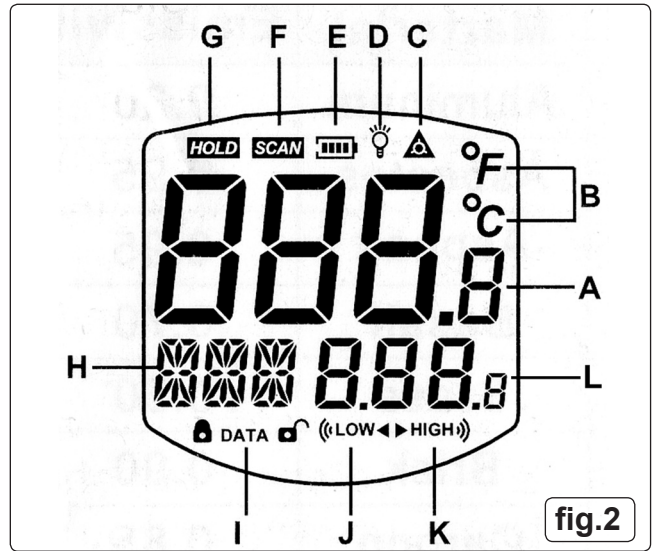

3.3. Buttons and Controls (fig.3)

1 - Trigger. Press to switch thermometer on. Press and hold to scan. The Temperature Reading (fig.2-A) and the Scanning icon (fig.2-F) will show on the LCD display. When the trigger is released, the last recorded Temperature Reading (fig.2-A) and the Data Hold icon (fig.2-G) will show.

Note! The thermometer will automatically switch off when not used for 30 seconds.

2 - Laser/Backlight Button. Press to operate the laser and the backlight. When the laser is on, the Laser On icon will show (fig.2-C). When the backlight is on, the Backlight On icon will show (fig.2-D). The backlight will only operate continually for 10 seconds.

3 - MODE Button. Press to navigate the mode menu. When the required mode is reached, press the SET button (4) to enter.

MAX mode - will display the maximum temperature measured on the Set/Record Value Indicator (fig.2-L) during a single scan.

MIN mode - will display the minimum temperature measured on the Set/Record Value Indicator (fig.2-L) during a single scan.

DIF mode - will display the difference between the highest and lowest measurements on the Set/Record Value Indicator (fig.2-L) during a single scan when the SET button (4) is pressed.

AVE mode - will display the average reading measured on the Set/Record Value Indicator (fig.2-L) during a single scan.

HAL - High Temperature Alarm. Use the arrow buttons (5) to set a high temperature alarm reading on the Set/Record Value Indicator (fig.2-L) and enter using the SET button (4). When the pre-set temperature is exceeded during scanning, HIGH will show on the LCD display (fig.2-K) and the audio alarm will sound.

LAL - Low Temperature Alarm. Use the arrow buttons (5) to set a low temperature alarm reading on the Set/Record Value Indicator (fig.2-L) and enter using the SET button (4). When the pre-set temperature is exceeded during scanning, LOW will show on the LCD display (fig.2-J) and the audio alarm will sound.

STO - Data Storage. Press the STO button (6) and then the SET button (4), the data storage/read icon (Fig.2-I) will show on the LCD display and 1--- will show in the Set/Record Value Indicator (fig.2-L). To store the reading, press the STO button (6) and the Set/Record Value Indicator (fig.2-L) will show 2---, ready for the next reading to be stored. There are 12 groups available in the thermometer memory. Data can be recalled in normal measuring mode by pressing the STO button (6). To clear the memory press and hold the STO button (6) for 3 seconds.

EMS - Emissivity set-up mode. Use the arrow buttons (5) to alter the emissivity setting displayed in the Set/Record Value Indicator (fig.2-L). Press the SET button (4) to confirm selection. The default setting for EMS is 0.95.

4 - SET Button. This button is used to confirm mode selection or any settings made.

5 - Arrow Buttons. These buttons are used to alter settings in the HAL/LAL/EMS modes.

6 - STO Button. This button is used for various functions in the data storage mode.

7 - Temperature Unit Switch. Located in the battery compartment area in the handle, this switch converts between °C and °F.

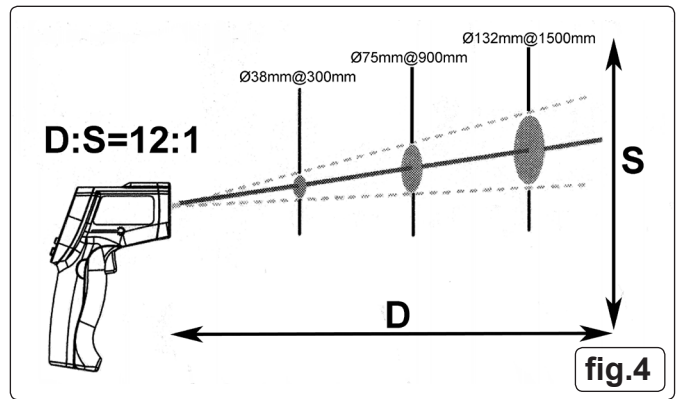
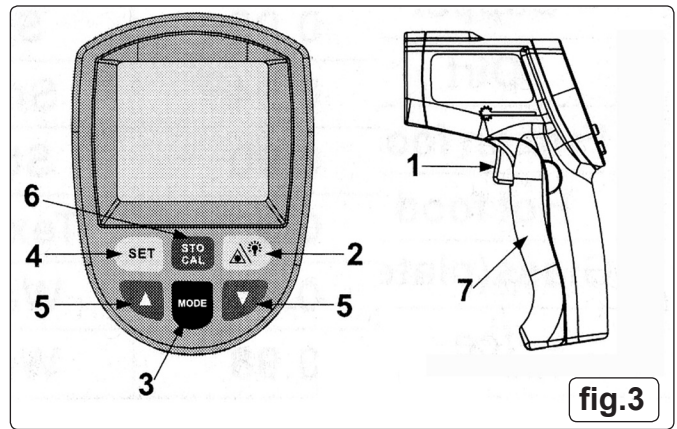

4. OPERATION

4.1. How the Unit Functions

4.1.1. The infrared thermometer measures the surface temperature of an object. The unit's optics sense emitted, reflected and transmitted energy which is collected and focused onto a detector. The unit's electronics translate the information into a temperature reading which appears on the LCD display. The laser is for aiming purposes only and plays no part in the temperature measurement.

4.2. Field of View (fig.4)

4.2.1. The unit's field of view is 12:1. This means that if the unit is positioned 300mm from the target the diameter of the object under test must be at least 38mm. As a general rule make sure that the target is larger than the relevant spot size. The smaller the spot size the closer you should be to the target. When accuracy is critical, make sure that the target is twice as large as the spot size.

4.3. Emissivity

4.3.1. Different materials and surfaces have different energy emitting characteristics (emissivity) but most organic materials and painted or oxidised surfaces are similar in this respect and the thermometer is designed to give correct readings for these materials and surfaces (Emissivity 0.95). To maintain accurate measurement, shiny or polished metal surfaces should be covered in masking tape or matt black paint before using the thermometer. Allow time for the tape/paint to attain the same temperature as the material beneath.

4.4. Obstructions

4.4.1. The thermometer cannot read the temperature of a target through glass or plastic sheet. It will only show the surface temperature of the sheet. Similarly, steam, dust or smoke will result in erroneous readings.

4.5. Operating the Thermometer

4.5.1. Hold the meter by its handle grip and point it towards the surface to be measured.

4.5.2. Pull and hold the trigger (fig.3-1) to turn the meter on and begin measuring. The Scanning icon (fig.2-F) and the Temperature Reading (fig.2-A) will show on the LCD display.

4.5.3. Whilst using the thermometer the following functions can be used:

a) Push the Laser/Backlight button (fig.3-2) to turn on the laser pointer. When the laser is 'on' the Laser On icon (fig.2-C) will appear on the LCD display. Aim the beam approximately 16mm above the point of test. (To turn the pointer 'off' press the Laser/Backlight button again.)

b) Select the temperature units using the Temperature Unit Switch (fig.3-7).

c) Push the Laser/Backlight button (fig.3-2) to turn on the LCD display backlight for a 10 second period.

4.5.4. Once the trigger has been released the information on the LCD display will remain for 30 seconds before the unit automatically switches off.

(Whilst the information remains on the LCD display the Data Hold icon (fig.2-G) will be displayed).

4.6. Locating a Hot Spot (fig.5)

4.6.1. To find a hot spot aim the thermometer outside the area of interest, then scan across with an up and down motion until you locate a hot spot.

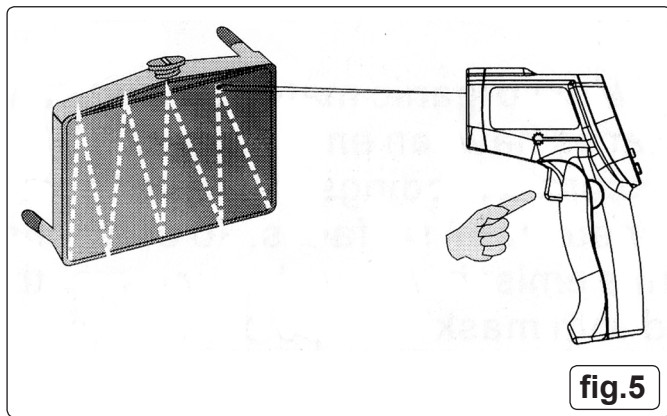

5.2. Heater

5.2.1. With the engine running, and at normal operating temperature, A/C 'off' and heater controls 'on' measure the temperatures of the heater inlet and outlet hoses/pipes at the engine compartment bulkhead. The outlet hose/pipe should be approximately 10°C cooler than the inlet. If the differential is significantly more than this the flow through the heater core is restricted and the system should be investigated.

5.3. Radiator

5.3.1. When the engine is running at normal operating temperature, there should be an even temperature drop between the radiator inlet and outlet. Check the whole radiator surface for any 'cold' spots which would indicate a blockage.

5.4. Thermostat

5.4.1. Under normal operation the thermostat will open as the engine reaches operating temperature, releasing hot coolant into the hose linking the thermostat housing to the radiator.

5.4.2. Use the thermometer to monitor the hose temperature, adjacent to the thermostat housing, as the engine warms up to operating temperature (85°C-105°C).

5.4.3. If the hose temperature abruptly and quickly increases, the thermostat is functioning correctly.

5.4.4. If the temperature increases gradually and does not reach operating level, the thermostat has failed in the open condition (or is missing).

5.4.5. If the temperature does not rise at all the thermostat has failed in the closed condition or coolant is not flowing for some other reason (air lock, pump failure etc.) and further investigation is required.

5.4.6. A fluctuating temperature indicates a weak thermostat spring or air in the system.

5.5. Misfiring Cylinder (fig.6)

5.5.1. A misfiring cylinder (petrol or diesel) can be located by taking temperature readings of each branch of the exhaust manifold.

5.5.2. The cool branch will indicate the misfiring cylinder. The temperature difference will be most marked before the engine has warmed up and heat transfer has heated the cool branch.

5.5.3. One exhaust branch hotter than the rest (petrol) suggests weak mixture to that cylinder, which should be investigated (faulty injector, inlet manifold gasket leak, etc.).

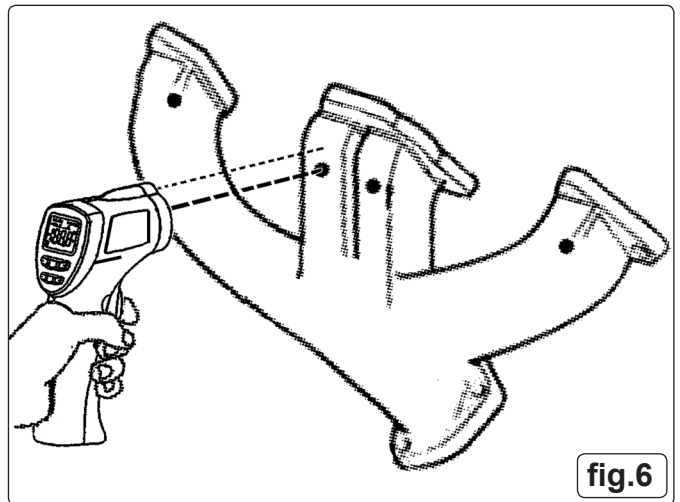

5. APPLICATIONS

❑ **WARNING!** When working on vehicle systems, take all the precautions necessary to ensure the safety of yourself and others - always refer to vehicle manufacturer's handbook/service manual. The purpose of this tool dictates that it will be used close to very hot equipment and therefore extreme care should be exercised.

5.1. Air Conditioning

5.1.1. With the air conditioning set to maximum cooling, the temperature of the output air should be at least 15°C colder than the outside ambient once the system has stabilised. **DO NOT** place the thermometer directly in the cold air stream (thermal shock) but rather hold it to one side and take the temperature of the air duct. If the air temperature differential is less than 15°C have the A/C system checked.

5.6. Catalytic Converter

5.6.1. With the engine at normal operating temperature and running at 1000rpm the inlet of the catalytic converter should be cooler than the outlet by >55°C (2-way converter) or >20°C (3-way converter).

5.6.2. If the outlet temperature is lower than the inlet then the converter is 'plugged' and must be replaced.

5.6.3. If the outlet temperature is the same as the inlet then the converter has reached the end of its service life (say 150,000 miles) or the converter material has broken up due to damage or has become contaminated.

5.6.4. Always determine the cause of failure, and rectify if appropriate, before fitting a replacement.

5.7. Brakes

5.7.1. The thermometer can be used to check comparative brake performance. The brakes should be brought up to operating temperature, by braking the vehicle from 30mph to a halt five times in quick succession, and the brake disc/drum temperatures then measured immediately.

5.7.2. Brakes on the same axle should not differ by more than 3°C and front brakes should be hotter than rear brakes by about 30°C. In the case of temperatures not meeting these criteria further investigation will be required - noting that it is normally the cooler brake which is faulty (seized, contaminated, etc.).

5.8. Tyres (fig.7)

5.8.1. A correctly inflated tyre will have the same temperature across the tread, within 10°C. To check, drive the car for a few miles and then measure the tread in three places.

5.8.2. If the readings from the sides of the tread are higher than that from the centre the tyre is probably under-inflated. Conversely over-inflation causes the centre to be hotter than the edges. In either case, adjust the tyre pressure in 2psi steps until even temperatures are achieved.

5.8.3. If the resulting pressure is significantly different from that recommended by the vehicle/tyre manufacturer look for another cause of the temperature difference (worn, damaged or misaligned suspension). Note that edge-of-tread temperatures which are significantly different from each other indicate a suspension fault.

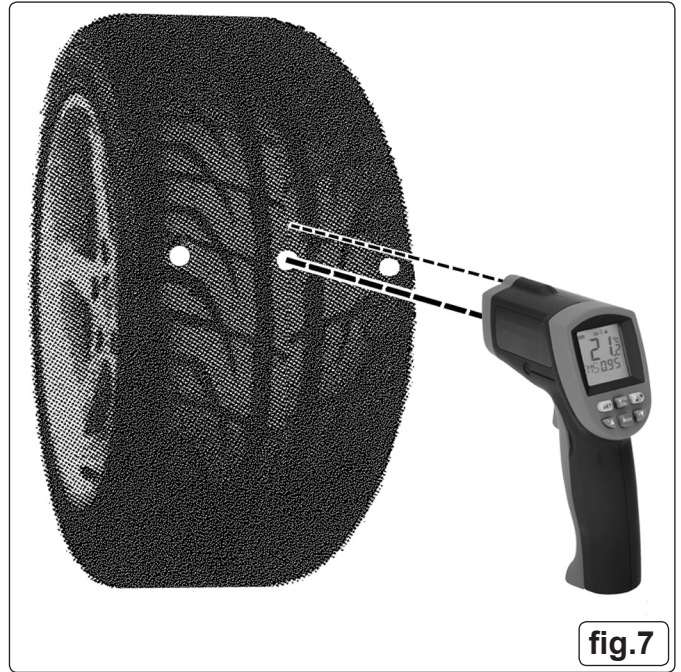

Environmental Protection.



Recycle unwanted materials instead of disposing of them as waste.

All tools, accessories and packaging should be sorted, taken to a recycle centre and disposed of in a manner which is compatible with the environment.



When the product is no longer required, it must be disposed of in an environmentally protective way. Contact your local solid waste authority for recycling information.



Open battery compartment as described in Section 3.1. Disconnect battery and remove.

Dispose of batteries according to local authority guidelines.

Under the Waste Batteries and Accumulators Regulations 2009, Jack Sealey Ltd are required to inform potential purchasers of products containing batteries (as defined within these regulations), that they are registered with Valpak's registered compliance scheme. Jack Sealey Ltd's Batteries Producer Registration Number (BPRN) is BPRN00705

NOTE: It is our policy to continually improve products and as such we reserve the right to alter data, specifications and component parts without prior notice.

IMPORTANT: No liability is accepted for incorrect use of this product.

WARRANTY: Guarantee is 12 months from purchase date, proof of which will be required for any claim.

INFORMATION: For a copy of our latest catalogue and promotions call us on 01284 757525 and leave your full name and address, including postcode.



Sole UK Distributor, Sealey Group,
Kempson Way, Suffolk Business Park,
Bury St. Edmunds, Suffolk,
IP32 7AR



01284 757500



01284 703534



www.sealey.co.uk



sales@sealey.co.uk